

E. Linear Ball Bearing

www.tbimotion.com.tw

1. About Linear Ball Bearing

LM Series Specifications (Standard)

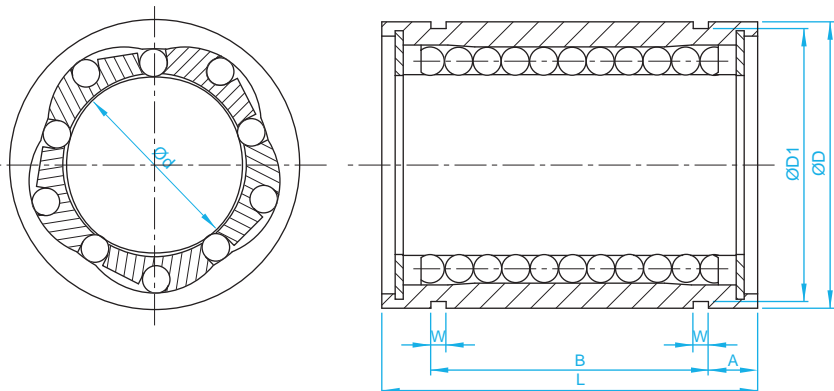

LM-L Series Specifications (Lengthen)

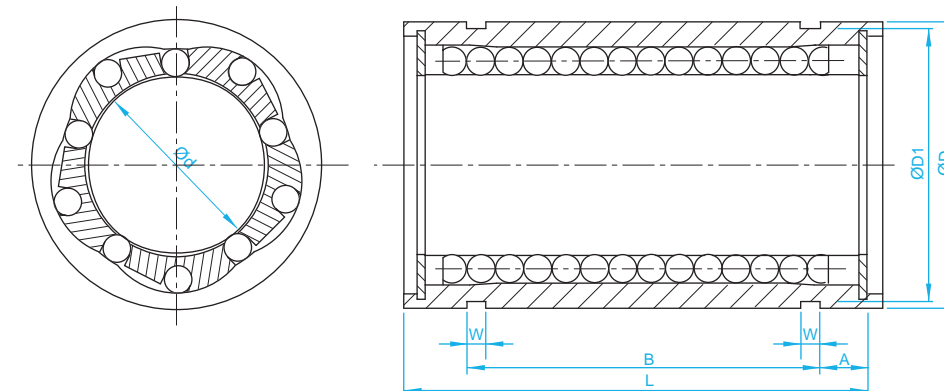

Unit : mm

Model No.	Dimension									Ca (kgf)	Coa (kgf)	Weight(g)
	d	D	D Tolerance (μm)	L	L Tolerance (μm)	W	D1	B	A			
LM-04UU	4	8	0	12	0	-	-	-	-	9	13	2
LM-06UU	6	12		19		1.1	11.5	13.5	2.75	21	27	8
LM-08UU	8	15	-11	24	0	1.1	14.3	17.5	3.25	27	41	16
LM-10UU	10	19		29		1.3	18	22	3.5	38	56	30
LM-12UU	12	21	-13	30	-20	1.3	20	23	3.5	42	61	31.5
LM-16UU	16	28		37		1.6	27	26.5	5.25	79	120	69
LM-20UU	20	32	0	42	0	1.6	30.5	30.5	5.75	88	140	87
LM-25UU	25	40		59		1.85	38	41	9	100	159	220
LM-30UU	30	45	-16	64	0	1.85	43	44.5	9.75	159	279	250
LM-40UU	40	60		80		2.1	57	60.5	9.75	219	409	585
LM-50UU	50	80	-19	100	-30	2.6	76.5	74	13	389	808	1580

※UU with oil seals in ends ※

Unit : mm

Model No.	Dimension									Ca (kgf)	Coa (kgf)	Weight(g)
	d	D	D Tolerance (μm)	L	L Tolerance (μm)	W	D1	B	A			
LM-06LUU	6	12	0	35	0	1.1	11.5	27	4	33	54	16
LM-08LUU	8	15	-13	45		1.1	14.3	35	5	44	80	31
LM-10LUU	10	19	0	55	-30	1.3	18	44	5.5	60	112	62
LM-12LUU	12	21		57		1.3	20	46	5.5	83	160	80
LM-16LUU	16	28	-16	70	0	1.6	27	53	8.5	126	240	145
LM-20LUU	20	32		80		1.6	30.5	61	9.5	143	280	180
LM-25LUU	25	40	0	112	-40	1.85	38	82	15	159	320	440
LM-30LUU	30	45		123		1.85	43	89	17	254	560	580
LM-40LUU	40	60	0	151	-40	2.1	57	121	15	350	820	1170
LM-50LUU	50	80		192		2.6	76.5	148	22	620	1622	3100

※UU with oil seals in ends ※

LF Series Specifications (Flange Type)

LF-L Series Specifications (Flange Type with Lengthen Nut)

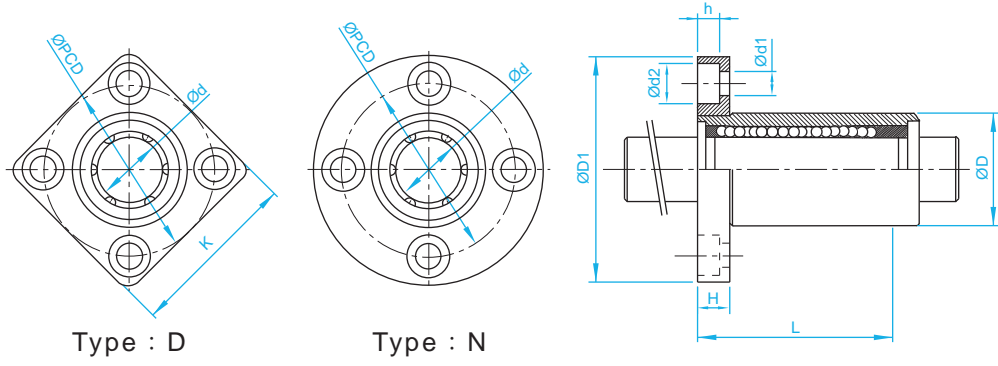
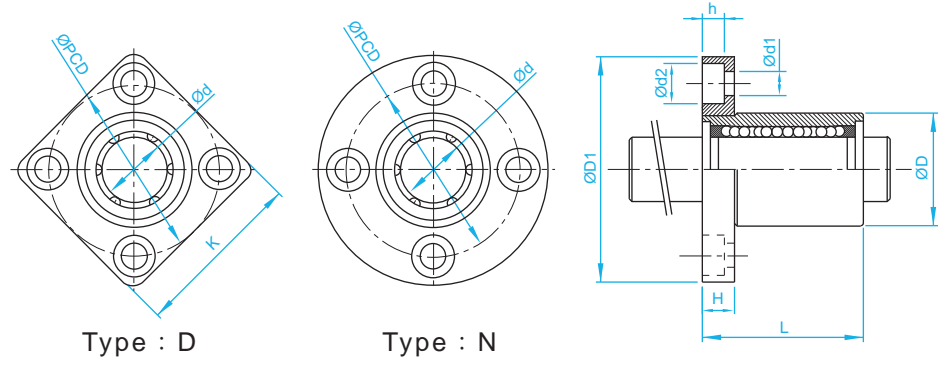

Unit : mm

Unit : mm

Model No.	Dimension											Ca (kgf)	Coa (kgf)	Weight(g)	
	d	D	D Tolerance (μm)	L	L Tolerance (μm)	D1	PCD	H	K	d1	d2				h
LF-06UU	6	12	0	19	0	28	20	5	22	3.5	6	3.1	21	27	8
LF-08UU	8	15	-11	24		32	24	5	25	3.5	6	3.1	28	40	16
LF-10UU	10	19	0	29		40	29	6	30	4.5	7.5	4.1	38	56	30
LF-12UU	12	21	-13	30		42	32	6	32	4.5	7.5	4.1	52	80	31.5
LF-16UU	16	28		37		48	38	6	37	4.5	7.5	4.1	79	120	69
LF-20UU	20	32	0	42		54	43	8	42	5.5	9	5.1	90	140	87
LF-25UU	25	40	-16	59	62	51	8	50	5.5	9	5.1	100	159	220	
LF-30UU	30	45		64	74	60	10	58	6.6	11	6.1	159	279	250	
LF-40UU	40	60	0	80	96	78	13	75	9	14	8.1	218	409	585	
LF-50UU	50	80	-19	100	116	98	13	92	9	14	8.1	389	808	1580	

Model No.	Dimension											Ca (kgf)	Coa (kgf)	Weight(g)	
	d	D	D Tolerance (μm)	L	L Tolerance (μm)	D1	PCD	H	K	d1	d2				h
LF-06LUU	6	12	0	35	0	28	20	5	22	3.5	6	3.1	33	54	16
LF-08LUU	8	15	-13	45		32	24	5	25	3.5	6	3.1	44	80	31
LF-10LUU	10	19	0	55		40	29	6	30	4.5	7.5	4.1	60	112	62
LF-12LUU	12	21	-16	57		42	32	6	32	4.5	7.5	4.1	83	160	80
LF-16LUU	16	28		70		48	38	6	37	4.5	7.5	4.1	126	240	145
LF-20LUU	20	32	0	80		54	43	8	42	5.5	9	5.1	143	280	180
LF-25LUU	25	40	-19	112	62	51	8	50	5.5	9	5.1	159	320	440	
LF-30LUU	30	45		123	74	60	10	58	6.6	11	6.1	254	560	580	
LF-40LUU	40	60	0	151	96	78	13	75	9	14	8.1	350	820	1170	
LF-50LUU	50	80	-22	192	116	98	13	92	9	14	8.1	620	1622	3100	

※UU with oil seals in ends ※

※UU with oil seals in ends ※

LINEAR BALL BEARING

LU/LP Series Specifications (Aluminum Housing Type)

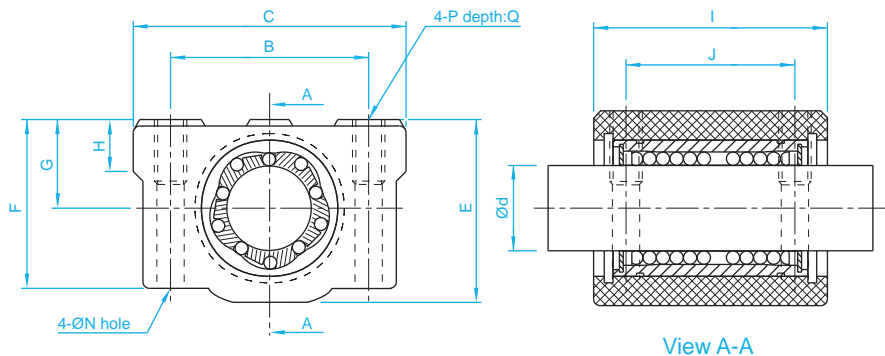

SF/WV Series Specifications (Shaft)

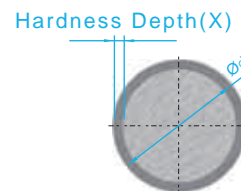

Material : CF53/S55C/SUJ2
 Hardness : HRC60Up
 Surface : Ra0.15-0.35µm
 Shaft Straightness : approx.0.1mm/m

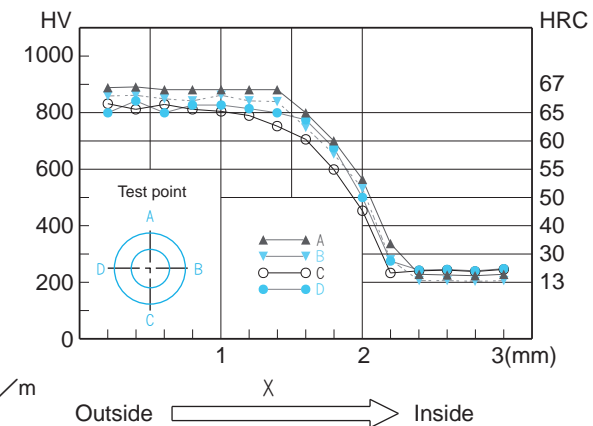

Unit : mm

Model No.	Dimension												Weight(g)
	d	B	C	E	F	G ±0.02	H	I	J	N	P	Q	
LU-08UU LP-08	8	24	34	22	18	11	6	30	18	3	M4	8	56
LU-10UU LP-10	10	28	40	26	21	13	8	35	21	4	M5	12	90
LU-12UU LP-12	12	30.5	42	29	25	15	8	36	26	4	M5	12	112
LU-16UU LP-16	16	36	50	38.5	35	19	9	44	34	4	M5	12	189
LU-20UU LP-20	20	40	54	42	36	21	11	50	40	5	M6	12	237
LU-25UU LP-25	25	54	76	51.5	41	26	12	67	50	6	M8	18	555
LU-30UU LP-30	30	58	78	59.5	49	30	15	72	58	6	M8	18	685
LU-40UU LP-40	40	80	102	78	62	40	20	90	60	8	M10	25	1600
LU-50UU LP-50	50	100	122	102	80	52	25	110	80	8	M10	25	3350

※LP-No Linear ball bearing is included.※

Unit : mm

Model No.	d	Hardness Depth (X)
★ SF-04	4	1.0
★ SF-06	6	1.0
★ SF-08	8	1.0
★ SF-10	10	1.0
★ SF-12	12	1.6
★ SF-16	16	1.6
★ SF-20	20	2.2
★ SF-25	25	2.2
★ SF-30	30	2.2
★ SF-32	32	2.2
★ SF-40	40	3.5
★ SF-50	50	3.5

※★can supply Chromium plated slide shaft (Model No. WV).※

SS Series Specifications (Shaft Support)

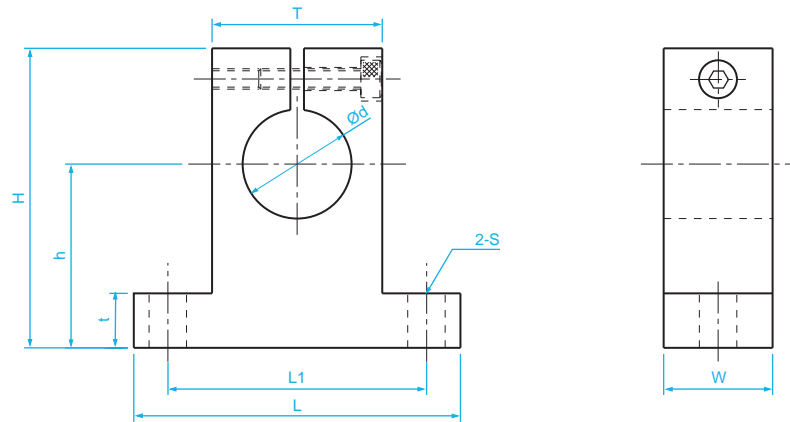

Unit : mm

Model No.	Dimension									Weight(g)
	d	h	L	W	H	t	T	L1	S	
SS-04	4	20	42	14	32.8	6	18	32	5.5	24
SS-06	6	20	42	14	32.8	6	18	32	5.5	24
SS-08	8	20	42	14	32.8	6	18	32	5.5	24
SS-10	10	20	42	14	32.8	6	18	32	5.5	24
SS-12	12	23	42	14	37.5	6	20	32	5.5	30
SS-16	16	27	48	16	44	8	25	38	5.5	40
SS-20	20	31	60	20	51	10	30	45	6.6	70
SS-25	25	35	70	24	60	12	38	56	6.6	130
SS-30	30	42	84	28	70	12	44	64	9	180
SS-40	40	60	114	36	96	15	60	90	11	420
SS-50	50	70	126	40	120	18	74	100	14	750

F. Support Unit of Ball Screw

www.tbimotion.com.tw

BK/EK/FK/BF/EF/FF



Surface Treatment : Black Oxidation

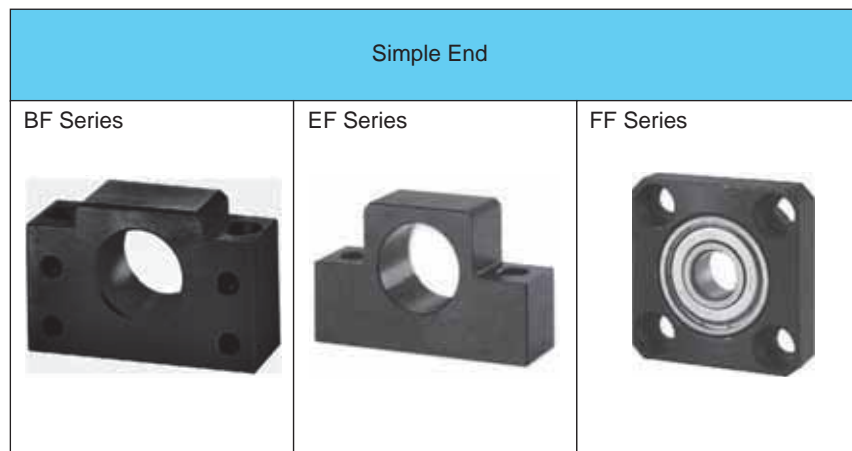

Surface Treatment : Black Oxidation

Table 1.1.1 Types of Support and Suggested Diameter of Ball Screw

Fixed End Model			Simple End Model			Suggested Diameter
Flange Type	Square Type		Flange Type	Square Type		
-	EK-6	-	FF-6	EF-6	-	Ø4, Ø6
FK-8	EK-8	-	FF-8	EF-8	-	Ø8, Ø10, Ø12
FK-10	EK-10	BK-10	FF-10	EF-10	BF-10	Ø10, Ø12, Ø14, Ø15
FK-12	EK-12	BK-12	FF-12	EF-12	BF-12	Ø14, Ø15, Ø16
FK-15	EK-15	BK-15	FF-15	EF-15	BF-15	Ø18, Ø20
-	-	BK-17	-	-	BF-17	Ø20, Ø25
FK-20	EK-20	BK-20	FF-20	EF-20	BF-20	Ø25, Ø28
FK-25	EK-25	BK-25	FF-25	EF-25	BF-25	Ø32, Ø36
FK-30	-	BK-30	FF-30	-	BF-30	Ø36, Ø40
-	-	BK-35	-	-	BF-35	Ø40, Ø45, Ø50
-	-	BK-40	-	-	BF-40	Ø50, Ø55

Table 1.1.2 Function

Fixed End				Simple End			
Support Model	Bearing Model	Axial		Support Model	Bearing Model	Radial	
		Ca (kgf)	K (kgf/μm)			Ca (kgf)	Coa (kgf)
EK-6	706ATYDF	273	2.9	EF-6, FF-6	606ZZ	231	88
EK-8, FK-8	708ATYDF	450	5.4	EF-8, FF-8	606ZZ	231	88
BK-10, EK-10, FK-10	7000ATYDF	620	9.6	BF-10, EF-10, FF-10	608ZZ	335	142
BK-12, EK-12, FK-12	7001ATYDF	679	10.6	BF-12, EF-12, FF-12	6000ZZ	465	200
BK-15, EK-15, FK-15	7002ATYDF	775	11.5	BF-15, EF-15, FF-15	6002ZZ	570	289
BK-17	7203ATYDF	1397	12.7	BF-17	6203ZZ	979	469
BK-20	7004ATYDF	1295	14.2	BF-20	6004ZZ	958	515
EK-20, FK-20	7204ATYDF	1820	15.8	EF-20, FF-20	6204ZZ	1300	702
BK-25, EK-25, FK-25	7205ATYDF	2060	19.4	BF-25, EF-25, FF-25	6205ZZ	1430	800
BK-30, FK-30	7206ATYDF	2856	19.8	BF-30, FF-30	6206ZZ	1989	1152
BK-35	7207ATYDF	3794	26.0	BF-35	6207ZZ	2621	1560
BK-40	7208ATYDF	4498	27.5	BF-40	6208ZZ	2968	1815

1-1 Installing Ball Screw with Support Units

- (1) Install the fixed end Support Unit with the screw shaft.
 - ※ Do not disassemble the Support Unit.
 - ※ When assembling the screw shaft to the Support Unit, make sure that the dimension between machine ends and bearing is matched.
- (2) After inserting the fixed end Support Unit, secure the lock nut using the fastening set piece and the hexagonal socket-head setscrews.
 - ※ Please contact TBI for special condition of mounting methods.
- (3) Attach the simple end bearing to the screw shaft and secure the bearing using the C-Ring.

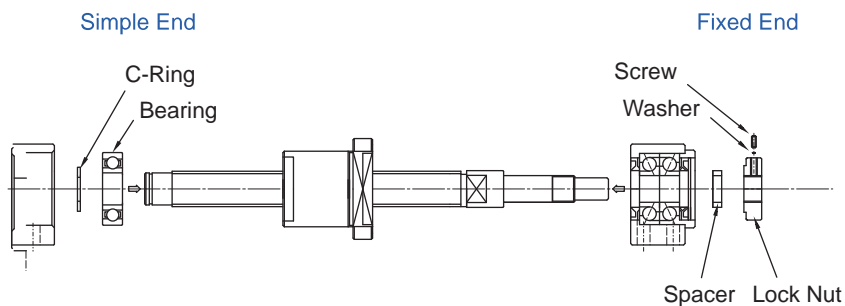

Fig 1.1.1

1-2 Assemble the Nut Bracket

- (1) If using a bracket when mounting the ball screw nut to the table, insert the nut into the bracket and fasten it temporarily.
- (2) Fasten the fixed end Support Unit to the base.
- (3) Ensure parallelism through reference face (linear guide) and ballscrew, then tighten both fixed and simple ends.
- (4) Move the table between both ends the Unit to align the axial center, and adjust the table so that the table can travel smoothly.

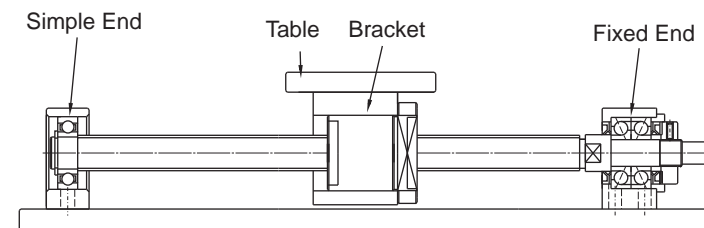

Fig 1.2.1

1-3 Checking Geometric Accuracy

- (1) While checking the runout of the ball screw shaft end and the axial clearance using a dial gauge.

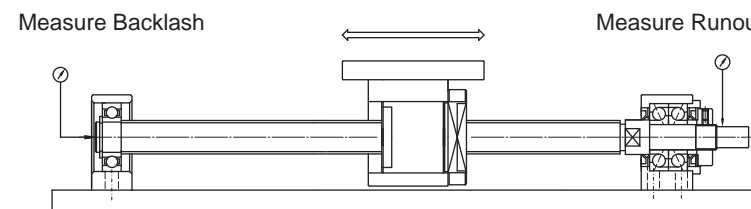

Fig 1.3.1

1-4 Connect Ball Screw Motor

- (1) Mount the motor bracket to the base.
- (2) Connect the motor and the ball screw using a coupling.
 - (Make sure the mounting accuracy is maintained).
- (3) Thoroughly perform the break-in for the system.

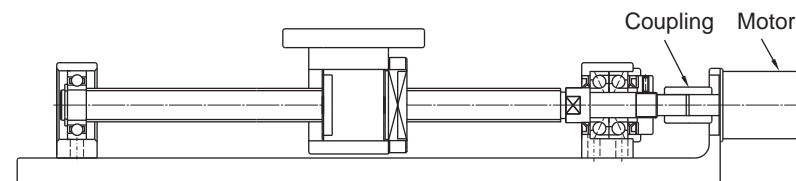
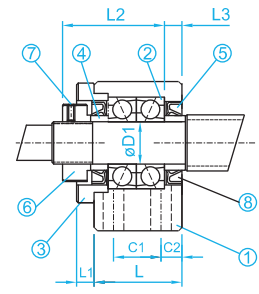
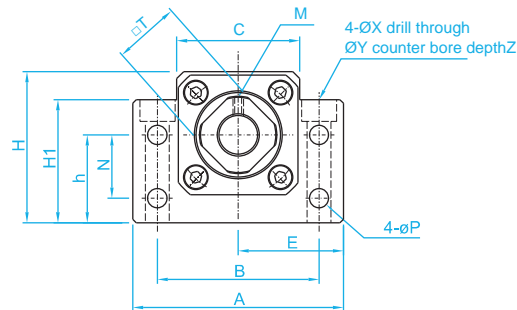

Fig 1.4.1

BK Series (Fixed End)



Code	Items	pcs
①	Housing	1 PCS
②	Bearing	1 SET
③	Lid	1 PCS
④	Spacer	2 PCS
⑤	Seal	2 PCS
⑥	Lock Nut	1 PCS
⑦	Screw with Washer	1 PCS

Unit: mm

Model No.	D1	A	B	C	C1	C2	E	H1	h	H
							±0.02		±0.02	
BK-10	10	60	46	34	13	6	30	32.5	22	39
BK-12	12	60	46	35	13	6	30	32.5	25	43
BK-15	15	70	54	40	15	6	35	38	28	48
BK-17	17	86	68	50	19	8	43	55	39	64
BK-20	20	88	70	52	19	8	44	50	34	60

L	L1	L2	L3	T	P	N	M	X	Y	Z	Bearing Model
25	5	29	5	16	5.5	15	M3	6.6	11	5	7000ATYDFC8P5
25	5	29	5	19	5.5	18	M3	6.6	11	1.5	7001ATYDFC8P5
27	6	32	6	22	5.5	18	M3	6.6	11	6.5	7002ATYDFC8P5
35	9	44	7	24	6.6	28	M4	9	14	8.5	7203ATYDFC8P5
35	8	43	8	30	6.6	22	M4	9	14	8.5	7004ATYDFC8P5

Suggest Dimension of End Machining

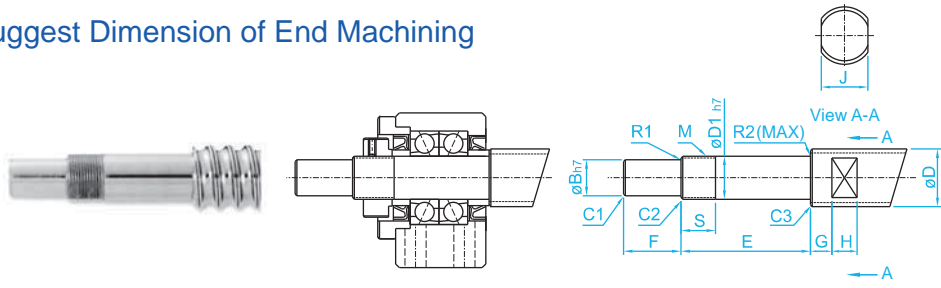

Model No.	Diameter	D1	B	E	F	M
BK-10	Ø12, Ø14, Ø15	10	8	39	15	M10x1
BK-12	Ø14, Ø15, Ø16, Ø18	12	10	39	15	M12x1
BK-15	Ø18, Ø20	15	12	40	20	M15x1
BK-17	Ø20, Ø25	17	15	53	23	M17x1
BK-20	Ø25, Ø28	20	17	53	25	M20x1

Tolerance

Dimension (mm)		h unit 0.001
Above	Under	h
6	10	-2 -15
10	18	-3 -18
18	24	-3 -21

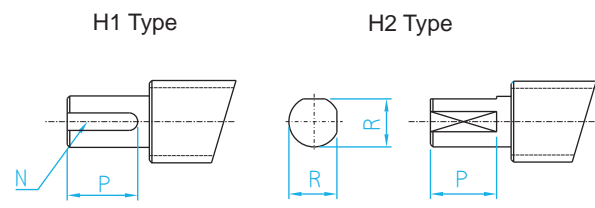

S	J	G	H	Chamfering			Circular Radius		H1 Keyway(WxDxL)		H2		Model BK
				C1	C2	C3	R1	R2	N	P	R	P	
16	10	5	7	0.5	0.5	0.5	0.3	0.6	2x1.2	11	7.5	11	BK-10
14	13	6	8	0.5	0.5	0.5	0.3	0.6	3x1.8	12	9.5	12	BK-12
12	16	6	9	0.5	0.5	0.5	0.3	0.6	4x2.5	16	11.3	16	BK-15
17	18	7	10	0.5	0.5	0.5	0.3	0.6	5x3.0	21	14.3	21	BK-17
15	21	8	11	0.5	0.5	0.5	0.5	0.6	5x3.0	21	16	21	BK-20

SUPPORT UNIT OF BALL SCREW

BK Series (Fixed End)

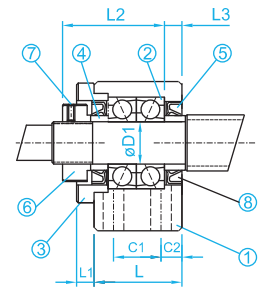
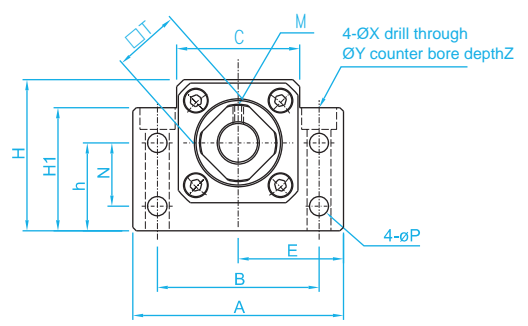

Code	Items	pcs
①	Housing	1 PCS
②	Bearing	1 SET
③	Lid	1 PCS
④	Spacer	2 PCS
⑤	Seal	2 PCS
⑥	Lock Nut	1 PCS
⑦	Screw with Washer	1 PCS

Unit: mm

Model No.	D1	A	B	C	C1	C2	E	H1	h	H
							±0.02		±0.02	
BK-25	25	106	85	64	22	10	53	70	48	80
BK-30	30	128	102	76	23	11	64	78	51	89
BK-35	35	140	114	88	26	12	70	79	52	96
BK-40	40	160	130	100	33	14	80	90	60	110

L	L1	L2	L3	T	P	N	M	X	Y	Z	Bearing Model
42	12	54	9	35	9	33	M5	11	175	11	7205ATYDFC8P5
45	14	61	9	40	11	33	M6	14	20	13	7206ATYDFC8P5
50	14	67	12	50	11	35	M8	14	20	13	7207ATYDFC8P5
61	18	76	15	50	14	37	M8	18	26	175	7208ATYDFC8P5

Suggest Dimension of End Machining

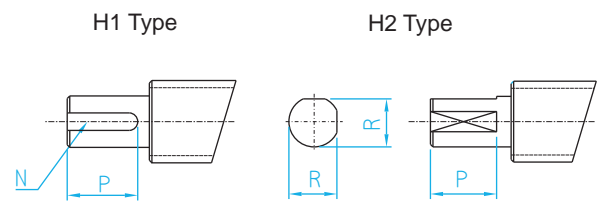
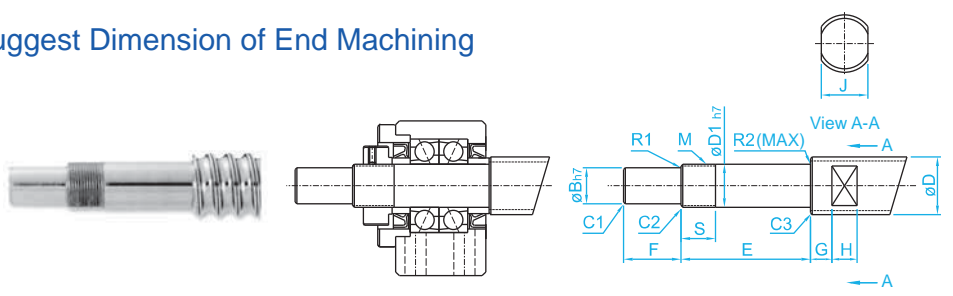

Tolerance

Dimension (mm)		h unit 0.001
Above	Under	h
18	30	-3 -21
30	50	-4 -25

Model No.	Diameter	D1	B	E	F	M
BK-25	Ø32, Ø36	25	20	65	30	M25x1.5
BK-30	Ø36, Ø40	30	25	72	38	M30x1.5
BK-35	Ø40, Ø45, Ø50	35	30	83	45	M35x1.5
BK-40	Ø50, Ø55	40	35	98	50	M40x1.5

S	J	G	H	Chamfering			Circular Radius		H1 Keyway(WxDxL)		H2		Model BK
				C1	C2	C3	R1	R2	N	P	R	P	
18	27	10	13	0.5	0.7	1.0	0.5	0.6	6x3.5	25	19	25	BK-25
25	32	10	15	0.5	0.7	1.0	0.5	1.0	8x4.0	32	23.5	32	BK-30
28	36	12	15	0.5	1.0	1.0	0.5	1.0	8x4.0	40	28.5	40	BK-35
35	41	14	19	0.5	1.0	1.0	0.5	1.0	10x5.0	45	33	45	BK-40

SUPPORT UNIT OF BALL SCREW

BF Series (Simple End)

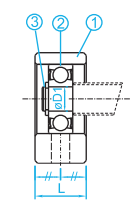
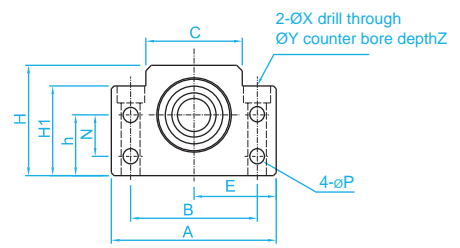

Code	Items	pcs
①	Housing	1 PCS
②	Bearing	1 PCS
③	C-Ring	1 PCS

Unit: mm

Model No.	D1	A	B	C	E	H1	h	H
					±0.02		±0.02	
BF-10	8	60	46	34	30	32.5	22	39
BF-12	10	60	46	35	30	32.5	25	43
BF-15	15	70	54	40	35	38	28	48
BF-17	17	86	68	50	43	55	39	64
BF-20	20	88	70	52	44	50	34	60
BF-25	25	106	85	64	53	70	48	80
BF-30	30	128	102	76	64	78	51	89
BF-35	35	140	114	88	70	79	52	96
BF-40	40	160	130	100	80	90	60	110

L	N	P	X	Y	Z	C-Ring	Bearing Model
20	15	5.5	6.6	11	5	C8	608ZZ
20	18	5.5	6.6	11	1.5	C10	6000ZZ
20	18	5.5	6.6	11	6.5	C15	6002ZZ
23	28	6.6	9	14	8.5	C17	6203ZZ
26	22	6.6	9	14	8.5	C20	6004ZZ
30	33	9	11	17.5	11	C25	6205ZZ
32	33	11	14	20	13	C30	6206ZZ
32	35	11	14	20	13	C35	6207ZZ
37	37	14	18	26	17.5	C40	6208ZZ

Suggest Dimension of End Machining

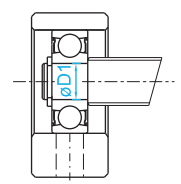

Model No.	Diameter	D1	E
BF-10	Ø12, Ø14, Ø15	8	10
BF-12	Ø14, Ø15, Ø16	10	11
BF-15	Ø18, Ø20	15	13
BF-17	Ø20, Ø25	17	16
BF-20	Ø25, Ø28	20	16
BF-25	Ø32, Ø36	25	20
BF-30	Ø36, Ø40	30	21
BF-35	Ø40, Ø45, Ø50	35	22
BF-40	Ø50, Ø55	40	23

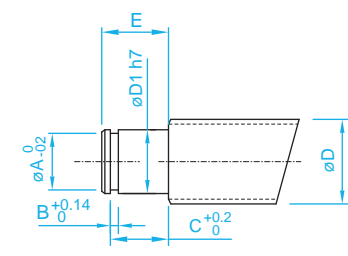

Tolerance

Dimension (mm)		h unit 0.001
Above	Under	h
6	10	-2 -15
10	18	-3 -18
18	30	-3 -21
30	50	-4 -25

C-Ring			Model BF
A	B	C	
7.6	0.9	7.9	BF-10
9.6	1.15	9.15	BF-12
14.3	1.15	10.15	BF-15
16.2	1.15	13.15	BF-17
19.0	1.35	13.35	BF-20
23.9	1.35	16.35	BF-25
28.6	1.75	17.75	BF-30
33.0	1.75	18.75	BF-35
38.0	1.95	19.95	BF-40

SUPPORT UNIT OF BALL SCREW

EK Series (Fixed End)

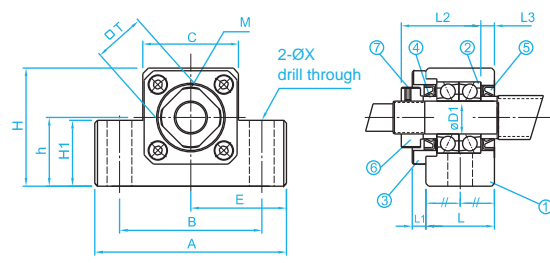
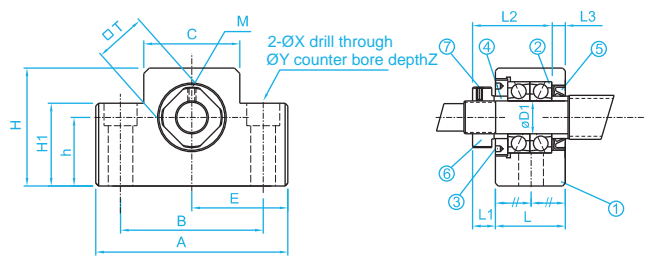

EK10~15

Code	Items	pcs
①	Housing	1 PCS
②	Bearing	1 SET
③	Lid	1 PCS
④	Spacer	2 PCS
⑤	Seal	2 PCS
⑥	Lock Nut	1 PCS
⑦	Screw with Washer	1 PCS

Unit:mm

Model No.	D1	A	B	C	E	H1	h
					±0.02		±0.02
EK-6	6	42	30	18	21	20	13
EK-8	8	52	38	25	26	26	17
EK-10	10	70	52	36	35	24	25
EK-12	12	70	52	36	35	24	25
EK-15	15	80	60	41	40	25	30

H	L	L1	L2	L3	M	X	Y	Z	T	Bearing Model
25	20	5.5	22	3.5	M3	5.5	9.5	11	12	706ATYDFC7P5
32	23	7	26	4	M3	6.6	11	12	14	708ATYDFC8P5
43	24	6	29.5	6	M3	9	-	-	16	7000ATYDFC8P5
43	24	6	29.5	6	M3	9	-	-	19	7001ATYDFC8P5
49	25	6	36	5	M3	11	-	-	22	7002ATYDFC8P5

Suggest Dimension of End Machining

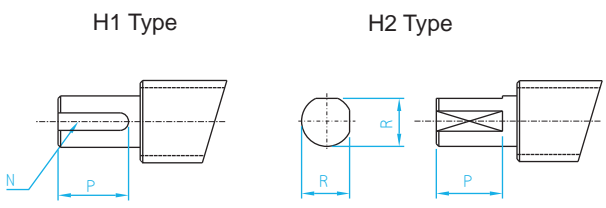
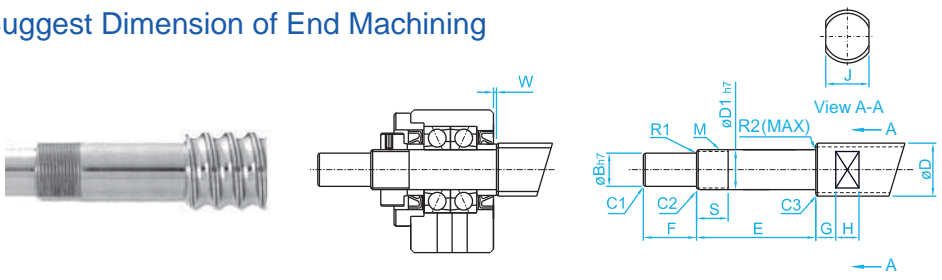

Tolerance

Dimension (mm)		h unit 0.001
Above	Under	h
6	10	-2 -15
10	18	-3 -18
18	24	-3 -21

Model No.	Diameter	D1	B	E	F	M
EK-6	Ø6, Ø8	6	4	30	8	M6x0.75
EK-8	Ø10, Ø12	8	6	35	9	M8x1
EK-10	Ø12, Ø14, Ø15	10	8	36	15	M10x1
EK-12	Ø14, Ø15, Ø16	12	10	36	15	M12x1
EK-15	Ø18, Ø20	15	12	49	20	M15x1

S	J	G	H	Chamfering			Circular Radius		H1 Keyway(WxDxL)		H2		W	Model EK
				C1	C2	C3	R1	R2	N	P	R	P		
10	5	4	4	0.3	0.3	0.3	0.3	0.6	-	-	3.7	6	1.5	EK-6
10	8	5	5	0.3	0.3	0.3	0.3	0.6	-	-	5.6	7	1.5	EK-8
11	10	5	7	0.5	0.5	0.5	0.3	0.6	2x1.2	11	7.5	11	-0.5	EK-10
11	13	6	8	0.5	0.5	0.5	0.3	0.6	3x1.8	12	9.5	12	-0.5	EK-12
13	16	6	9	0.5	0.5	0.5	0.3	0.6	4x2.5	16	11.3	16	5.0	EK-15

SUPPORT UNIT OF BALL SCREW

EK Series (Fixed End)

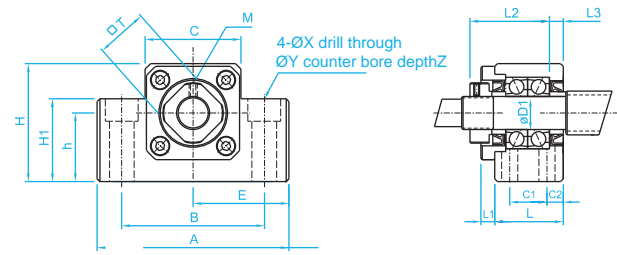

EK-20S

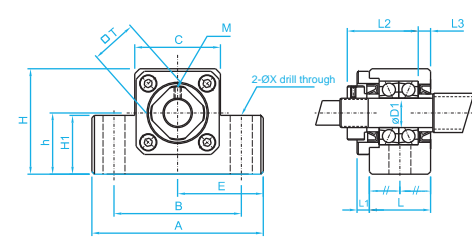

EK-20

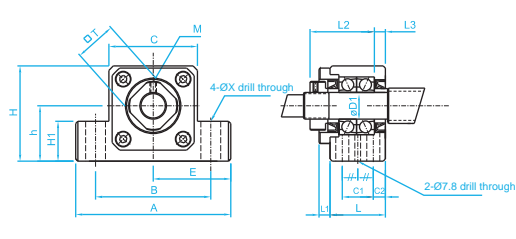

EK-25

Model No.	D1	A	B	C	E	H1	h
					±0.02		±0.02
EK-20	20	95	75	56	47.5	25	30
EK-25	25	105	85	66	52.5	25	35

Unit: mm

C2	C1	H	L	L1	L2	L3	M	X	Y	Z	T	Bearing Model
-	-	58	42	10	50	10	M4	11	-	-	30	7204ATYDFC8P5
9	30	68	48	13	60	14	M5	11	-	-	35	7205ATYDFC8P5

Suggest Dimension of End Machining

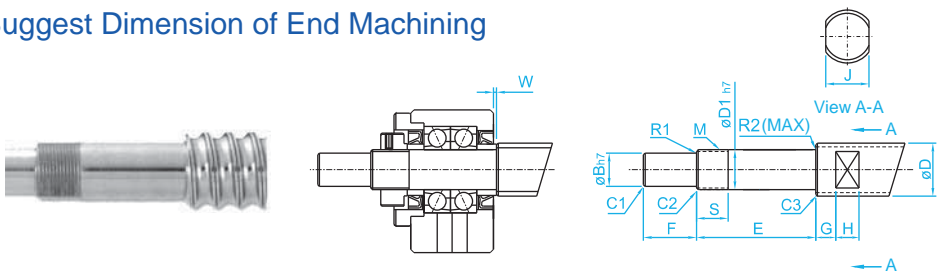

Model No.	Diameter	D1	B	E	F	M
EK-20	Ø25, Ø28, Ø32	20	17	64	25	M20x1
EK-25	Ø32, Ø36	25	20	65	30	M25x1.5

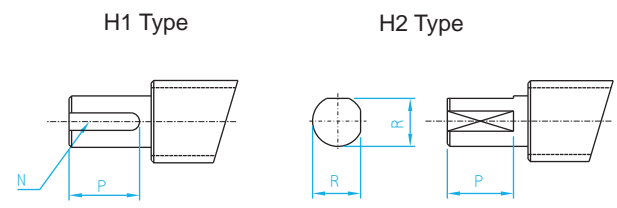

Tolerance

Dimension (mm)		h unit 0.001
Above	Under	h
6	10	-2 -15
10	18	-3 -18
18	24	-3 -21

S	J	G	H	Chamfering			Circular Radius		H1 Keyway(WxDxL)		H2		W	Model EK
				C1	C2	C3	R1	R2	N	P	R	P		
17	21	8	11	0.5	0.5	0.5	0.5	0.6	5x3.0	21	16	21	1.0	EK-20
18	27	10	13	0.5	0.7	1.0	0.5	0.6	6x3.5	25	19	25	1.0	EK-25

SUPPORT UNIT OF BALL SCREW

EF Series (Simple End)

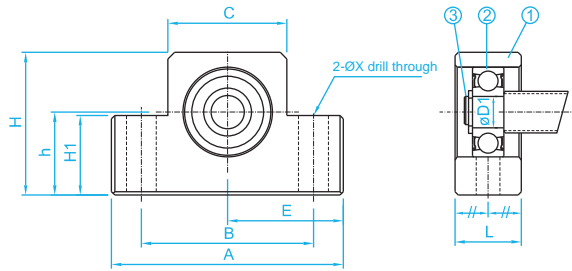

EF10~15, EF20~25

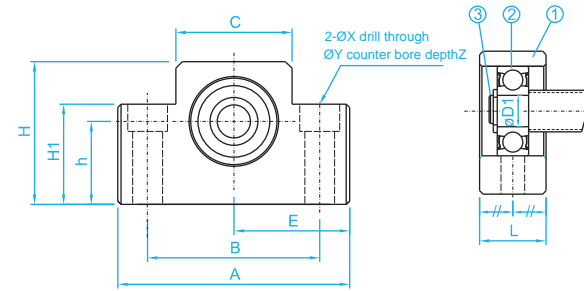

EF6~8

Code	Items	pcs
①	Housing	1 PCS
②	Bearing	1 PCS
③	C-Ring	1 PCS

Model No.	D1	A	B	C	E	H1	h
					±0.02		±0.02
EF-6	6	42	30	18	21	20	13
EF-8	6	52	38	25	26	26	17
EF-10	8	70	52	36	35	24	25
EF-12	10	70	52	36	35	24	25
EF-15	15	80	60	41	40	25	30
EF-20	20	95	75	56	47.5	25	30
EF-25	25	105	85	66	52.5	25	35

Unit:mm

H	L	X	Y	Z	C-Ring	Bearing Model
25	12	5.5	9.5	11	C6	606ZZ
32	14	6.6	11	12	C6	606ZZ
43	20	9	-	-	C8	608ZZ
43	20	9	-	-	C10	6000ZZ
49	20	9	-	-	C15	6002ZZ
58	26	11	-	-	C20	6204ZZ
68	30	-	11	-	C25	6205ZZ

Suggest Dimension of End Machining

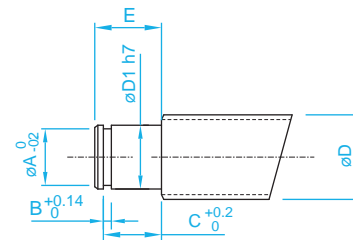

Tolerance

Dimension (mm)		h unit 0.001
Above	Under	h
6	10	-2 -15
10	18	-3 -18
18	24	-3 -21

Model No.	Diameter	D1	E
EF-6	Ø6, Ø8	6	9
EF-8	Ø10, Ø12	6	9
EF-10	Ø12, Ø14, Ø15	8	10
EF-12	Ø14, Ø15, Ø16	10	11
EF-15	Ø18, Ø20	15	13
EF-20	Ø25, Ø28	20	19
EF-25	Ø32, Ø36	25	20

C-Ring			Model EF
A	B	C	
5.7	0.8	6.8	EF-6
5.7	0.8	6.8	EF-8
7.6	0.9	7.9	EF-10
9.6	1.15	9.15	EF-12
14.3	1.15	10.15	EF-15
19	1.35	15.35	EF-20
23.9	1.35	16.35	EF-25

SUPPORT UNIT OF BALL SCREW

FK Series (Fixed End)

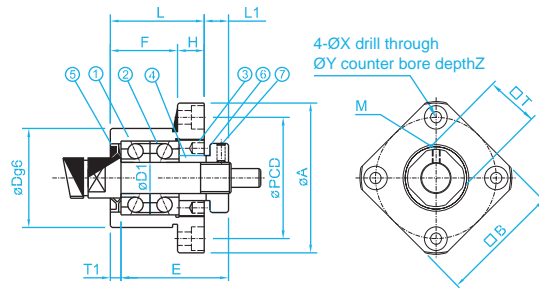

Method A

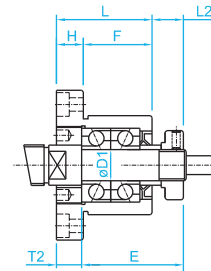

Method B

D	g6
28	-0.007 -0.020

Code	Items	pcs
①	Housing	1 PCS
②	Bearing	1 SET
③	Lid	1 PCS
④	Spacer	2 PCS
⑤	Seal	2 PCS
⑥	Lock Nut	1 PCS
⑦	Screw with Washer	1 PCS

Unit:mm

Model No.	D1	A	F	L	E	Dg6	H	PCD
FK-8	8	43	14	23	26	28	9	35

M	B	L1	T1	L2	T2	X	Y	Z	T	Bearing Model
M3	35	7	4	8	5	3.4	6.5	4	14	708ATYDFC8P5

Suggest Dimension of End Machining

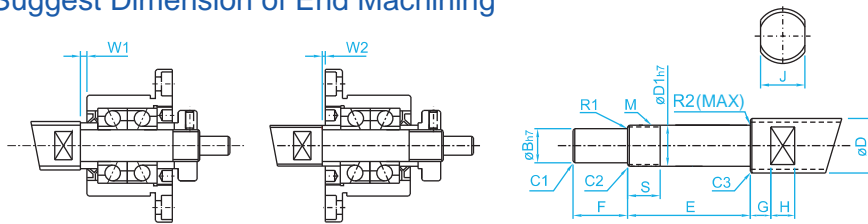

Model No.	Diameter	D1	B	E	F	M
FK-8	Ø10, Ø12	8	6	35	9	M8x1

H1 Type

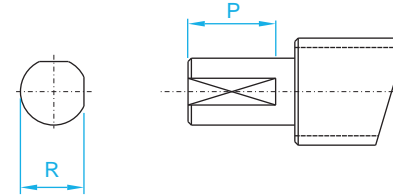

Tolerance

Dimension (mm)		h unit 0.001
Above	Under	h
6	10	-2 -15

S	Chamfering			Circular Radius		H1		W1	W2	Model FK
	C1	C2	C3	R1	R2	R	P			
15	0.5	0.5	0.5	0.3	0.6	5.6	7	1.5	0.5	FK-8

SUPPORT UNIT OF BALL SCREW

FK Series (Fixed End)

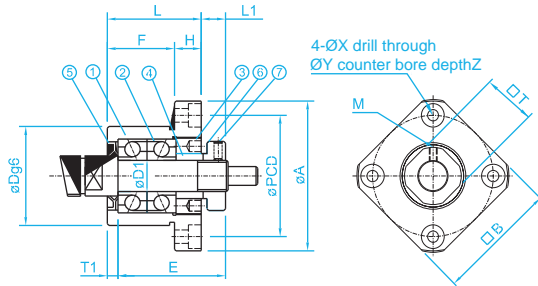

Method A

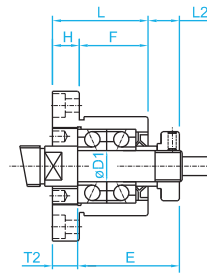

Method B

D	g6
34	-0.009 -0.025
36	-0.009 -0.025
40	-0.009 -0.025
57	-0.010 -0.029
63	-0.010 -0.029
75	-0.010 -0.029

Code	Items	pcs
①	Housing	1 PCS
②	Bearing	1 SET
③	Lid	1 PCS
④	Spacer	2 PCS
⑤	Seal	2 PCS
⑥	Lock Nut	1 PCS
⑦	Screw with Washer	1 PCS

Unit: mm

Model No.	D1	A	F	L	E	Dg6	H	PCD
FK-10	10	52	17	27	29.5	34	10	42
FK-12	12	54	17	27	29.5	36	10	44
FK-15	15	63	17	32	36	40	15	50
FK-20	20	85	30	52	50	57	22	70
FK-25	25	98	30	57	60	63	27	80
FK-30	30	117	32	62	61	75	30	95

M	B	L1	T1	L2	T2	X	Y	Z	T	Bearing Model
M3	42	7.5	5	8.5	6	4.5	8	4	16	7000ATYDFC8P5
M3	44	7.5	5	8.5	6	4.5	8	4	19	7001ATYDFC8P5
M3	52	10	6	12	8	5.5	9.5	6	22	7002ATYDFC8P5
M4	68	8	10	12	14	6.6	11	10	30	7204ATYDFC8P5
M5	79	13	10	20	17	9	15	13	35	7205ATYDFC8P5
M6	93	14	12	17	18	11	17.5	15	40	7206ATYDFC8P5

Suggest Dimension of End Machining

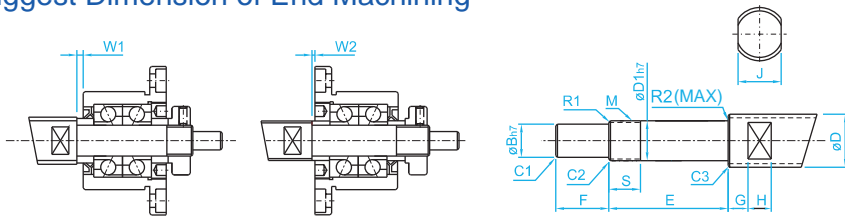

Model No.	Diameter	D1	B	E	F	M
FK-10	Ø12, Ø14, Ø15	10	8	36	15	M10x1
FK-12	Ø14, Ø15, Ø16	12	10	36	15	M12x1
FK-15	Ø18, Ø20	15	12	49	20	M15x1
FK-20	Ø25, Ø28	20	17	64	25	M20x1
FK-25	Ø32, Ø36	25	20	76	30	M25x1.5
FK-30	Ø40, Ø50	30	25	72	38	M30x1.5

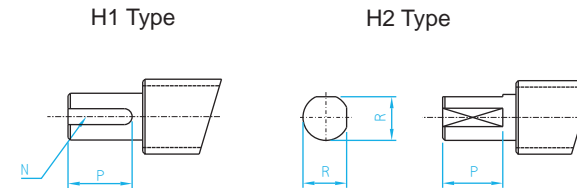

Tolerance

Dimension (mm)		h unit 0.001
Above	Under	h
6	10	-2 -15
10	18	-3 -18
18	30	-3 -21

S	J	G	H	Chamfering			Circular Radius		H1		H2		W1	W2	Model FK
				C1	C2	C3	R1	R2	N	P	R	P			
11	10	5	7	0.5	0.5	0.5	0.3	0.6	2x1.2	11	7.5	11	0.5	0.5	FK-10
11	13	6	8	0.5	0.5	0.5	0.3	0.6	3x1.8	12	9.5	12	0.5	0.5	FK-12
13	16	6	9	0.5	0.5	0.5	0.3	0.6	4x2.5	16	11.6	16	4	2	FK-15
17	21	8	11	0.5	0.5	0.5	0.5	0.6	5x3.0	21	16	21	1	-3	FK-20
20	27	10	13	0.5	0.5	0.5	0.5	0.6	6x3.5	25	19	25	5	-2	FK-25
25	32	10	15	0.5	0.5	0.5	0.5	0.6	8x4	32	23.5	32	-3	-6	FK-30

SUPPORT UNIT OF BALL SCREW

FF Series (Simple End)

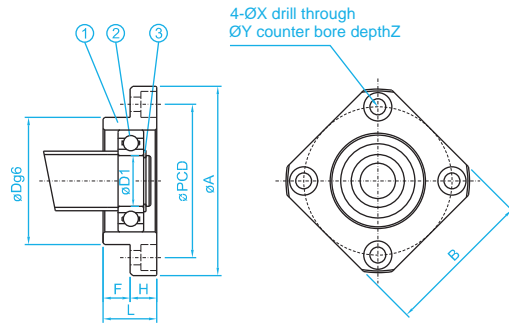

D	g6
22	-0.007 -0.020
28	-0.007 -0.020
34	-0.009 -0.025
40	-0.009 -0.025
57	-0.010 -0.029
63	-0.010 -0.029
75	-0.010 -0.029

Code	Items	pcs
①	Housing	1 PCS
②	Bearing	1 PCS
③	C-Ring	1 PCS

Model No.	D1	L	H	F	Dg6	A
FF-6	6	10	6	4	22	36
FF-10	8	12	7	5	28	43
FF-12	10	15	7	8	34	52
FF-15	15	17	9	8	40	63
FF-20	20	20	11	9	57	85
FF-25	25	24	14	10	63	98
FF-30	30	27	18	9	75	117

PCD	B	X	Y	Z	C-Ring	Bearing Model
28	28	3.4	6.5	4	C6	606ZZ
35	35	3.4	6.5	4	C8	608ZZ
42	42	4.5	8	4	C10	6000ZZ
50	52	5.5	9.5	5.5	C15	6002ZZ
70	68	6.6	11	6.5	C20	6204ZZ
80	79	9	14	8.5	C25	6205ZZ
95	93	11	17.5	11	C30	6206ZZ

Unit:mm

Suggest Dimension of End Machining

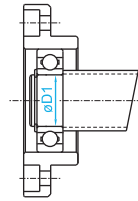
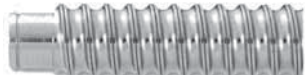

Model No.	Diameter	D1	E
FF-6	Ø10, Ø12	6	9
FF-10	Ø12, Ø14, Ø15	8	10
FF-12	Ø14, Ø15, Ø16	10	11
FF-15	Ø18, Ø20	15	13
FF-20	Ø25, Ø28	20	19
FF-25	Ø32, Ø36	25	20
FF-30	Ø40, Ø50	30	21

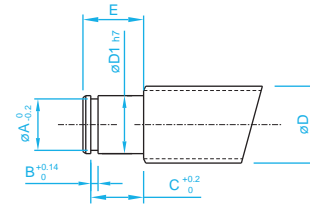

Tolerance

Dimension (mm)		h unit 0.001
Above	Under	h
6	10	-2 -15
10	18	-3 -18
18	24	-3 -21

C-Ring			Model FF
A	B	C	
5.7	0.8	6.8	FF-6
7.6	0.9	7.9	FF-10
9.6	1.15	9.15	FF-12
14.3	1.15	10.15	FF-15
19	1.35	15.35	FF-20
23.9	1.35	16.35	FF-25
28.6	1.75	17.75	FF-30

SUPPORT UNIT OF BALL SCREW

G. Coupling

www.tbimotion.com.tw

SRJ Specifications

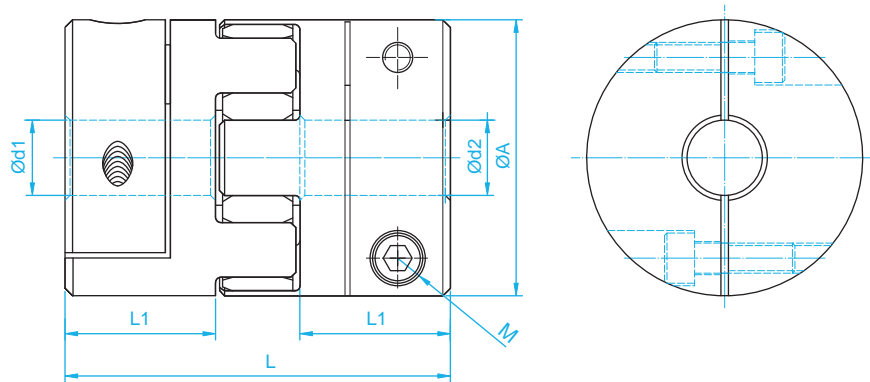

Unit: mm

Model No.	A	L	L1	dmax	(H8)d1xd2		M
					d1	d2	
SRJ-20C	20	30	10	10	5, 6, 6.35, 7, 8		M3
SRJ-30C	30	35	11	16	6, 6.35, 8, 9, 9.5, 10, 11, 12, 14		M4
SRJ-40C	40	66	25	22	10, 11, 12, 14, 15, 16		M5
SRJ-55C	55	78	30	28	15, 16, 18, 19, 20, 22, 24, 25		M6
SRJ-65C	65	90	35	38	15, 16, 18, 19, 20, 22, 24, 25, 28, 30, 32, 35		M8

※ Specifications Number : SRJ-AC-d1 x d2

※ Material : Aluminum Alloy

※ Buffer Material : Engineering Class Plastic

Function



Model No.	Rate Torque (N · m)	Max Torque (N · m)	Max Rotational Spring Rigidity (min ⁻¹)	Static Torsion Spring Rigidity (N · m/rad)	Dynamic Torsion Spring Rigidity (N · m/rad)
SRJ-20C	5	10	15200	51.0	151
SRJ-30C	12.5	25	10200	170.9	505
SRJ-40C	17	34	7600	857.5	2571
SRJ-55C	60	120	5600	2060	6163
SRJ-65C	160	320	4700	3430	10291

Model No.	Weight (g)		Mass Moment of Inertia J (kg·m ²)		Radial (mm)	Angular (°)	Axial (mm)
	each hub	spider	each hub	spider			
SRJ-20C	8.5	1.7	0.46x10 ⁻³	0.073x10 ⁻³	0.10	1.0	0.8
SRJ-30C	18	4.2	2.5x10 ⁻³	0.45x10 ⁻³	0.15	1.0	1
SRJ-40C	64	6.5	20.1x10 ⁻³	1.44x10 ⁻³	0.15	1.0	1.2
SRJ-55C	130	17.4	50.5x10 ⁻³	7.3x10 ⁻³	0.2	1.0	1.4
SRJ-65C	250	28.6	200.1x10 ⁻³	16.3x10 ⁻³	0.2	1.0	1.5

