

C-Lube Linear Way MLV

MLV



C-Lube Linear Way MLV

MLV



Long term maintenance free compliant!

The aquamarine end plate is the symbol of maintenance free.

Track rail

Slide unit

Casing

Circulation pipe

C-Lube

Ball

End plate

Scraper

Ball retaining band

Oil hole

Points

1 Extremely small size realized by simple structure

For details P.I-19

Super small-size linear motion rolling guide produced by two-row four-point contact simple structure and original small sizing technology.

2 Long term maintenance free

For details P.I-11

The built-in "C-Lube", the capillary lubricating element, in the ball circulation pipes of the slide unit makes it long term maintenance free.

Lubrication oil is continuously supplied to the surface of rolling elements by surface tension in the contact of the capillary lubricating element surface and rolling elements.

3 Cost performance

Preserving the basic performance of C-Lube Linear Way ML as is, lower cost has been achieved by reviewing the structure including the ball recirculation part.

4 Ball retained type for easy operation

The slide unit incorporates the ball retaining band, which prevents the ball from dropping down when the slide unit is removed from the track rail. This safety structure brings you an easy operation to the machines/equipment.

5 Stainless steel selections for excellent corrosion resistance

For details P.I-41

Stainless steel highly corrosion-resistant is used as the basic specification, so that the products are suitable for applications where rust prevention oil is not preferred, such as in cleanroom environment.

Identification Number and Specification

Example of an Identification Number

The specifications of the MLV series are indicated by the identification number. Indicate the identification number, consisting of a model code, dimensions, a part code, a classification symbol, and any supplemental codes for each specification to apply.

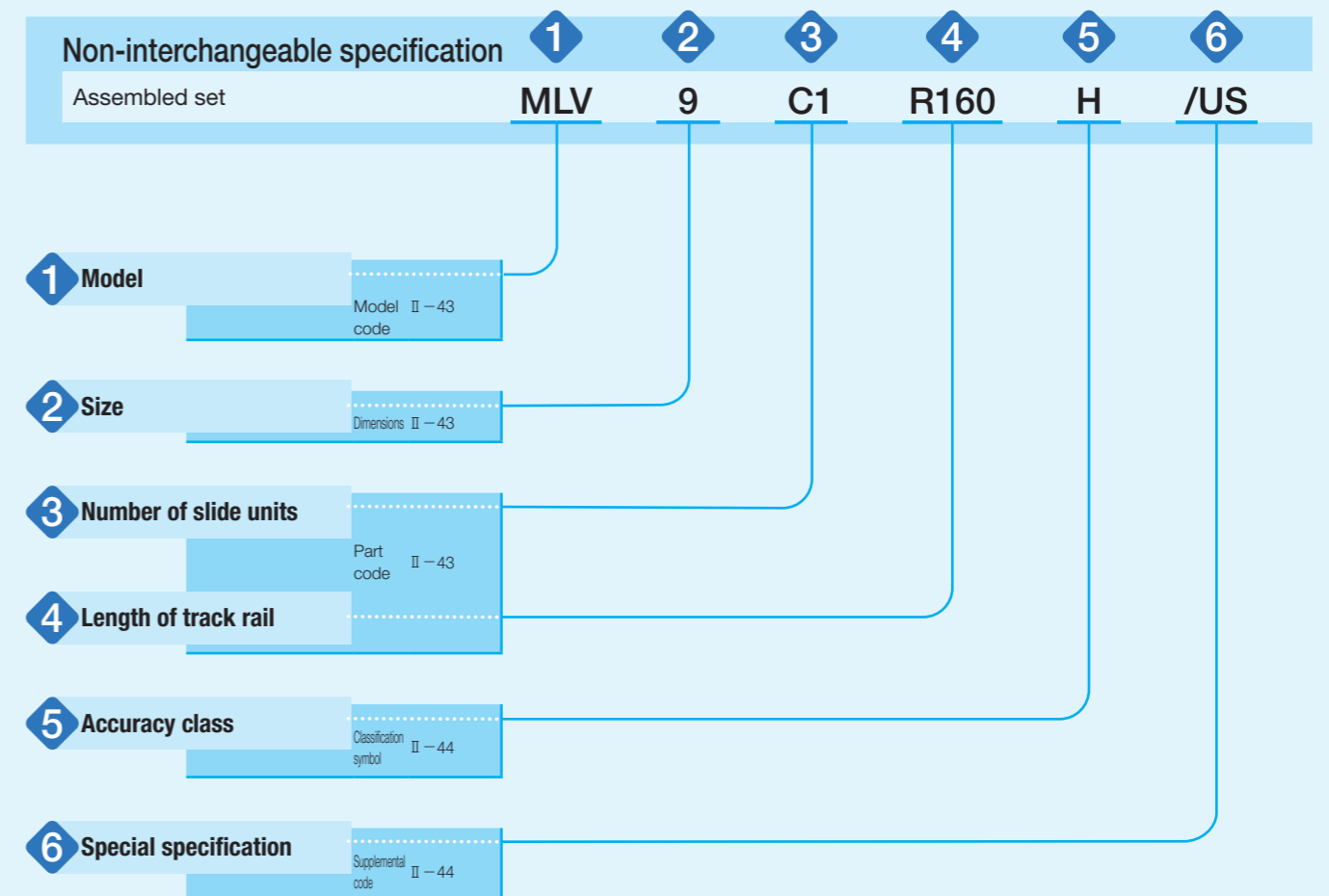

Identification Number and Specification — Model · Size · Number of Slide Unit · Length of Track Rail —

1 Model	C-Lube Linear Way MLV (MLV series)	: MLV
2 Size	7, 9, 12	
3 Number of slide units	: C○	Indicates the number of slide units assembled on a track rail.
4 Length of track rail	: R○	Indicate the length of track rail in mm. For standard and maximum lengths, see Table 1.

Table 1 Standard and maximum lengths of track rail

unit: mm

Identification number	MLV 7	MLV 9	MLV 12
Standard length L (n)	60 (4)	60 (3)	100 (4)
	90 (6)	80 (4)	150 (6)
	120 (8)	120 (6)	200 (8)
	150 (10)	160 (8)	275 (11)
	180 (12)	220 (11)	350 (14)
	240 (16)	280 (14)	475 (19)
Pitch of mounting holes F	15	20	25
E	7.5	10	12.5
Standard E dimensions	or higher	4.5	4.5
	below	12	14.5
Maximum length ⁽¹⁾	300 (990)	860 (1 200)	1 000 (1 450)

Note ⁽¹⁾ Length up to the value in () can be produced. If needed, please contact **IKO**.
 Remark: If not directed, E dimensions for both ends will be the same within the range of standard E dimensions. To change the dimensions, indicate the specified rail mounting hole positions "/ E " of special specification. For more information, see page III - 30.

— Accuracy Class · Special Specification —

5 Accuracy class	High	: H	For details of accuracy class, see Table 2.
-------------------------	------	-----	---

Table 2 Tolerance and allowance

Item	Class (Classification symbol)	High (H)
Dim. H tolerance		± 0.020
Dim. N tolerance		± 0.025
Dim. variation of H ⁽¹⁾		0.015
Dim. variation of N ⁽¹⁾		0.020
Parallelism in operation of the slide unit C surface to A surface		See Fig. 1.
Parallelism in operation of the slide unit D surface to B surface		See Fig. 1.

Note ⁽¹⁾ It means the size variation between slide units mounted on the same track rail.

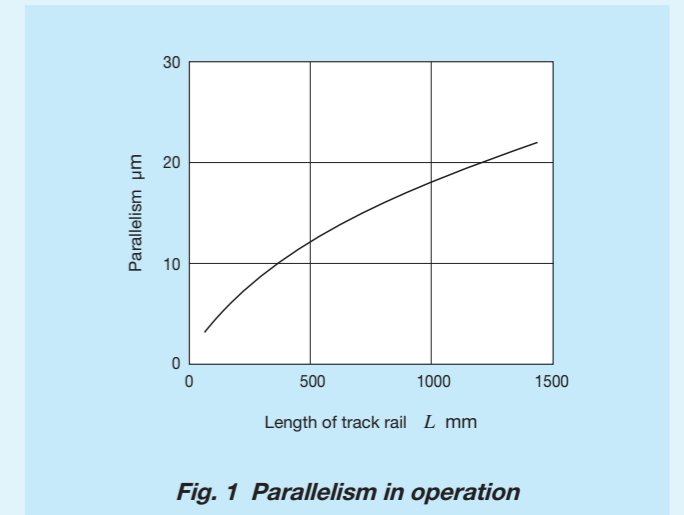

6 Special specification	/D, /E, /MN, /US, /W○, /YCG	For applicable special specifications, see Table 3. For combination of multiple special specifications, see Table 4. For details of special specifications, see page III - 29.
--------------------------------	-----------------------------	--

Table 3 Application of special specifications

Special specification	Supplemental code	Size		
		7	9	12
Opposite reference surfaces arrangement	/D	○	○	○
Specified rail mounting hole positions	/E	○	○	○
Without track rail mounting bolt	/MN	○	○	○
End seal	/US	○	○	○
A group of multiple assembled sets	/W○	○	○	○
Specified grease (Low Dust-Generation Grease for Clean Environment CG2)	/YCG	○	○	○

Table 4 Combination of supplemental codes

E	-				
MN	○	○			
US	○	○	○		
W	○	-	○	○	
YCG	○	○	○	○	○
	D	E	MN	US	W

Remarks: 1. The combination of "-" shown in the table is not available.
 2. When using multiple types for combination, please indicate by arranging the symbols in alphabetical order.

Preload

Preload for the MLV series is adjusted to have subtle clearance or minimal amount of preload.

Lubrication

Lithium-soap base grease (MULTEMP PS No.2 [KYODO YUSHI CO., LTD.]) is pre-packed in MLV series. Additionally, MLV series has C-Lube placed in the recirculation part of balls, so that the interval for reapplying lubricant can be extended and maintenance works such as grease job can be reduced significantly.

MLV series have an oil hole. (See Table 5)

Dedicated supplying equipment (miniature greasers) fit to oil holes are also available. For order of these parts for lubrication, see Table 13 on Page III-23.

Dust Protection

No end seal is provided for the MLV series. For applications in other than clean environment, cover the whole unit with a protective case, etc. to prevent harmful foreign substances such as dust and particles from entering.

We can also attach end seals (supplemental code "/US") on both sides of the slide unit. If needed, indicate the supplemental code.

Even with the use of the end seals to prevent dust from entering, if large amount of contaminants or dust are floating, or if large particles of foreign substances such as chips or sand may adhere to the track rail, it is recommended to attach a protective cover to the linear motion mechanism.

Table 5 Oil hole specifications

Size	d_1	d_2
7	0.5	1.2
9		1.5
12		2

Precaution for Use

1 Handling

A strong grip on the circulation pipes of the MLV series slide unit, will distort the circulation path, which may affect the operating performance; handle with care.

2 Mounting surface, reference mounting surface and typical mounting structure

When mounting the MLV series, properly align the reference mounting surfaces B and D of the track rail and the slide unit with the reference mounting surface of the table and the bed and fix them. (See Fig.2)

The reference mounting surfaces B and D and mounting surfaces A and C are precisely ground. Machining the mounting surface of the table and bed, such as machine or device, to high accuracy and mounting them properly will ensure stable linear motion with high accuracy.

Reference mounting surface of the slide unit is the upper surface when you see the mark on the C surface in normal position. The track rail reference mounting surface is identified by locating the mark on the top surface of the track rail. It is the side surface above the mark (in the direction the arrow point). (See Fig.3)

3 Shoulder height and corner radius of the reference mounting surface

For the opposite corner of the mating reference mounting, it is recommended to have relieved fillet as indicated in Fig. 4. Recommended value for the shoulder height on the mating side is indicated in Table 6.

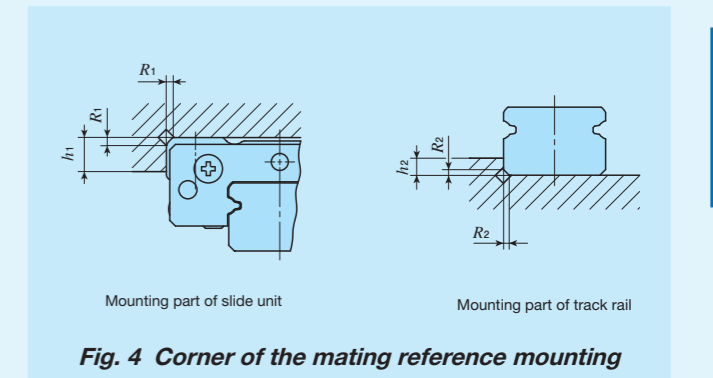

Table 6 Shoulder height and corner radius of the reference mounting surface

Size	Mounting part of slide unit		Mounting part of track rail	
	Shoulder height h_1	Corner radius R_1 (maximum)	Shoulder height h_2	Corner radius R_2 (maximum)
7	2.5	0.2	1.2	0.2
9	3	0.2	1.5	0.2
12	4	0.2	2.5	0.2

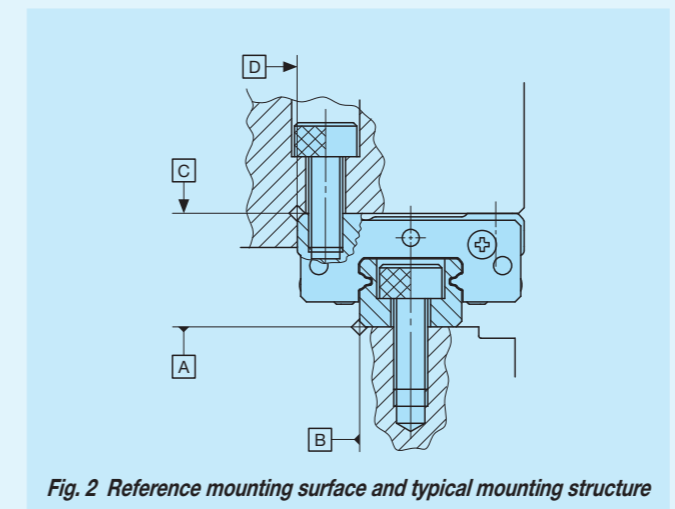

Fig. 2 Reference mounting surface and typical mounting structure

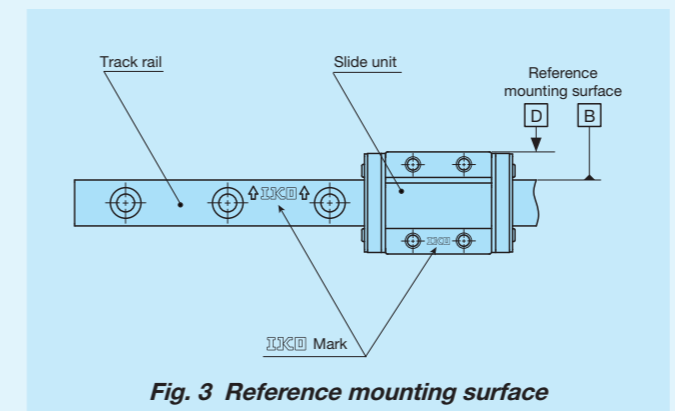

Fig. 3 Reference mounting surface

4 Tightening torque for fixing screw

Typical tightening torque for mounting of the MLV series to the steel mating member material is indicated in Table 7. When vibration and shock of the machine or device are large, fluctuating load is large, or moment load is applied, fix it by using the torque 1.2 to 1.5 times larger than the value indicated in the table as necessary. If the mating member material is cast iron or aluminum alloy, reduce the tightening torque depending on the strength characteristics of the mating member material.

Table 7 Tightening torque for fixing screw

Bolt size	Tightening torque N · m
	Stainless steel-made screw
M2×0.4	0.31
M3×0.5	1.1

Remark: The tightening torque is calculated based on the property division A2-70.

Standard type			
Shape	MLV		
Size	7	9	12

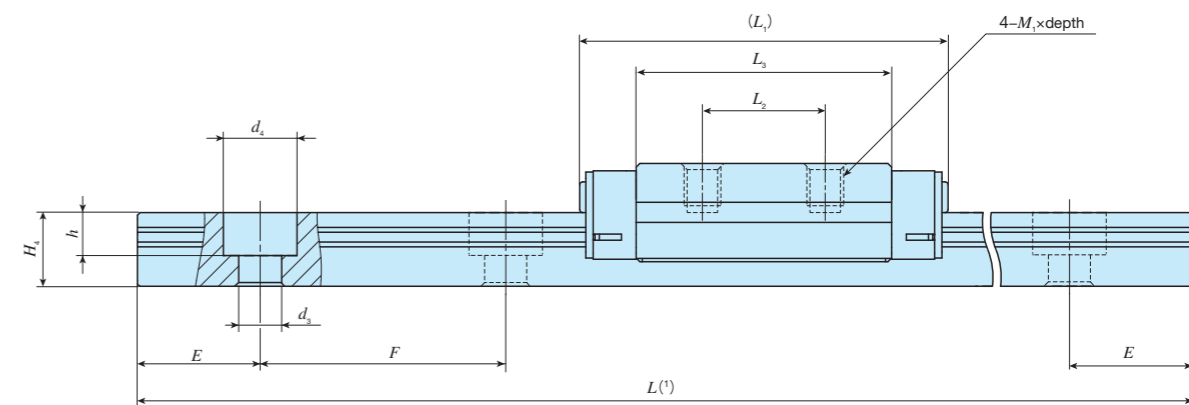
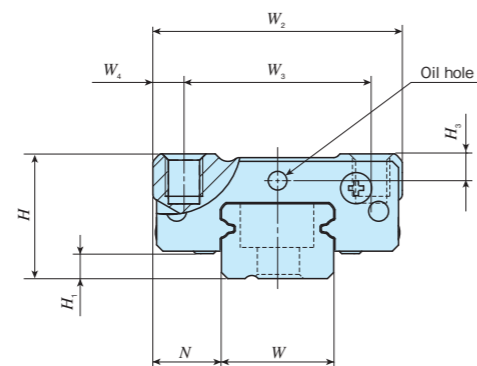

Identification number	Mass (Ref.) g		Dimensions of assembly mm			Dimensions of slide unit mm							Dimensions of track rail mm						Appended mounting bolt for track rail (2) mm Bolt size × ℓ	Basic dynamic load rating (3) C N	Basic static load rating (3) C ₀ N	Static moment rating (3)				
	Slide unit	Track rail (Per 100 mm)	H	H ₁	N	W ₂	W ₃	W ₄	L ₁	L ₂	L ₃	M ₁ × depth	H ₃	W	H ₄	d ₃	d ₄	h				E	F	T ₀ N · m	T _x N · m	T _y N · m
MLV 7	8.4	22	8	1.5	5	17	12	2.5	23.5	8	14.3	M2×2	1.5	7	5	2.4	4.2	2.3	7.5	15	M2×6	1 330	1 890	6.9	4.7 28.2	3.9 23.6
MLV 9	17	35	10	2	5.5	20	15	2.5	30	10	20.8	M3×3	2.2	9	6	3.5	6	3.5	10	20	M3×8	1 810	2 760	12.8	9.1 51.1	7.6 42.9
MLV 12	31	65	13	3	7.5	27	20	3.5	34	15	21.6	M3×3.5	2.7	12	8	3.5	6.5	4.5	12.5	25	M3×8	3 330	4 290	26.6	15.4 93.1	12.9 78.2

Notes (1) Track rail lengths L are shown in Table 1 on page II-43.
 (2) The appended track rail mounting bolts are stainless steel hexagon socket head bolts equivalent to JIS B 1176.
 (3) The direction of basic dynamic load rating (C), basic static load rating (C_0), and static moment rating (T_0 , T_x , T_y) are shown in the sketches below.
 The upper values of T_x and T_y are for one slide unit and the lower values are for two slide units in close contact.
 Remark: The specification of oil holes is shown in Table 5 on page II-45.

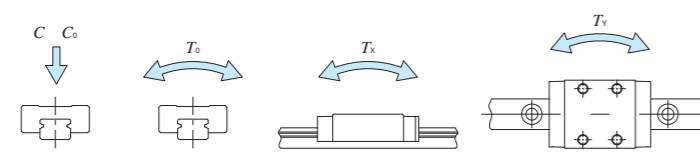

Example of identification number of assembled set

Model code	Dimensions	Part code	Classification symbol	Supplemental code
MLV	7	C2 R120	H	/US
①	②	③	④	⑤
① Model MLV C-Lube Linear Way MLV	② Size 7, 9, 12	③ Number of slide units (2)	④ Length of Track Rail (120mm)	⑤ Accuracy class H High
			⑥ Special specification D, E, MN, US, W, YCG	