

TM

TM

TM

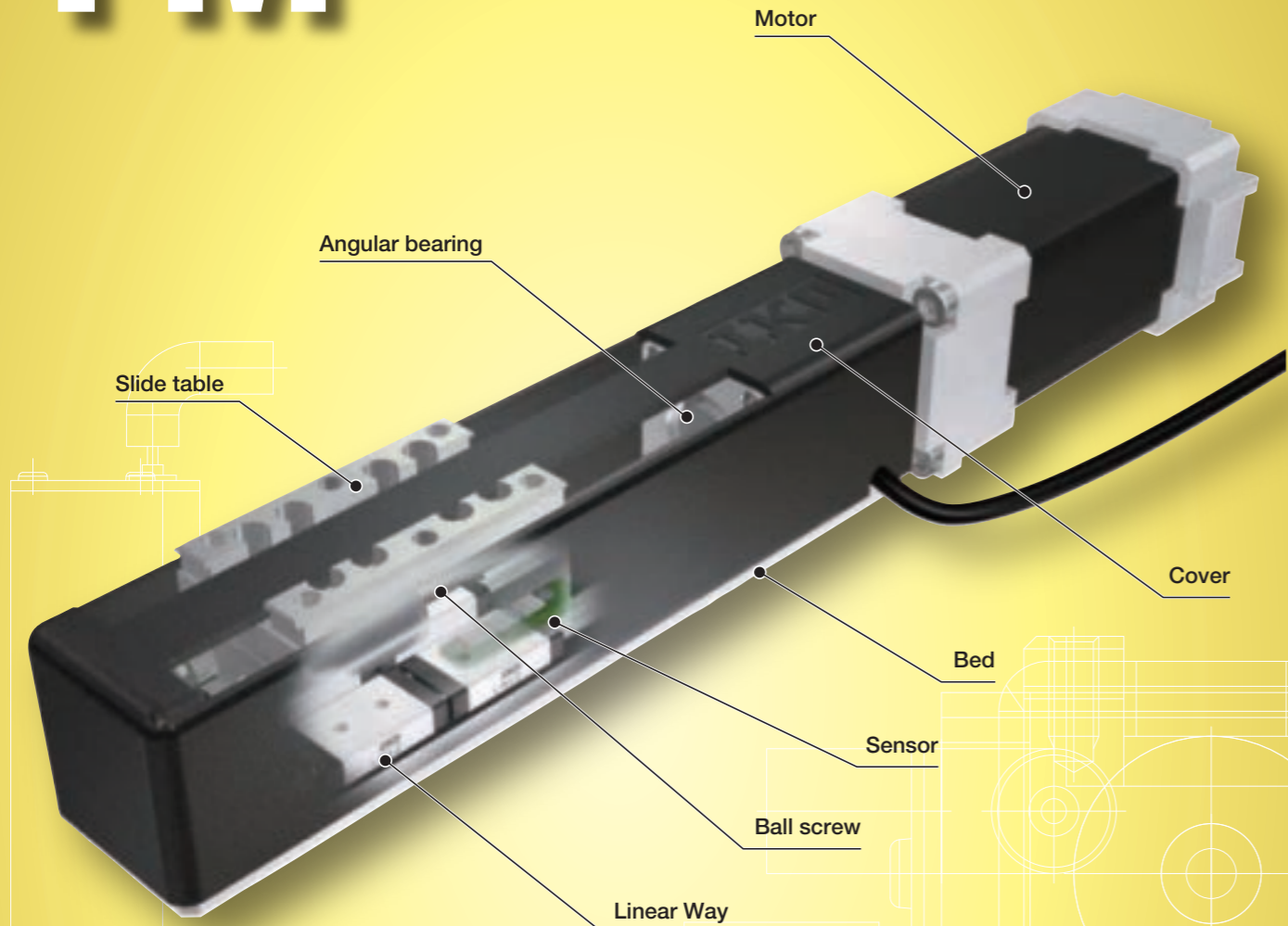
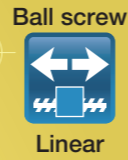

Major product specifications

Driving method	Precision ball screw
Linear motion rolling guide	Linear Way (ball type)
Built-in lubrication part	No built-in
Material of table and bed	Stainless steel
Sensor	Select by identification number

Accuracy

unit: mm

Positioning repeatability	±0.001~0.002
Positioning accuracy	0.015
Lost motion	-
Parallelism in table motion A	-
Parallelism in table motion B	-
Attitude accuracy	-
Straightness	-
Backlash	-

Points

● **Ground ball screw drive realizes ultra-small positioning table with sectional height of 20mm and width of 17mm.**

1 Incorporating a Micro Linear Way L of 2mm in rail width in the table guiding parts and a miniature ball screw of 2mm in diameter in the feeding mechanism, this is an unparalleled ultra-small size positioning table with ground ball screw drive type.

● **Table specification is selectable according to your use.**

3 There are two types in the shape of slide table: standard table and long table. As two Micro Linear Way L with two slide units are incorporated in parallel into the long table, the table is structurally resistant to moment and complex load. The motor can be selected from two types of AC servomotor (standard type or high torque type) and stepper motor according to your use.

● **Maximum table speed of 150mm/s is exerted.**

2 Combination of high-lead ball screws and high-torque AC servomotors enables the table to move at high speed without reducing the accuracy.

● **Super small sensor can also be optionally built in.**

4 Respective built-in sensors (origin, pre-origin, CW, and CCW) can be designed without changing outside dimension.

☑ **Widely applicable in such fields as below!**

Featuring the ultra-small size yet super precision positioning capability, this table is best suited to enhancing the accuracy of the positioning mechanism of super small device. And, use of stainless steel in steel parts allows the table to be used even in a location where use of oil and grease should be preferably avoided and under the environment that tends to suffer from water scattering.

Best suited for positioning mechanism of super small device!

- Measuring equipment
- Watch assembling machine
- Medical equipment
- Winder etc....
- Electronic parts assembling machine
- Bio-related equipment
- Robot

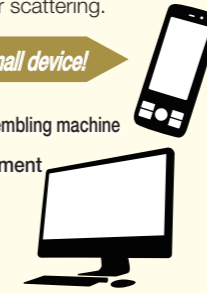

☑ **This table can respond to various requests!**

We can prepare tables of various specifications such as switching table specification, lead screw specification, and stainless steel cover specification, in order to meet customer needs. For more information, please contact **IKO**.

Example of special specification: Switching table specification

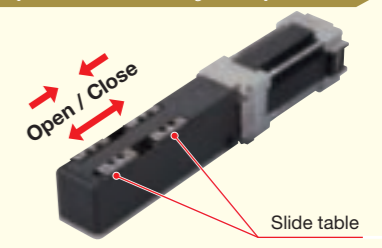

Variation

Shape	Model and size	Stroke length (mm)					
		10	20	30	40	50	60
 Standard table	TM15	-	☆	-	☆	-	☆
	Long table	TM15G	☆	-	☆	-	☆

1N=0.102kgf=0.2248lbs.
1mm=0.03937inch

Identification Number

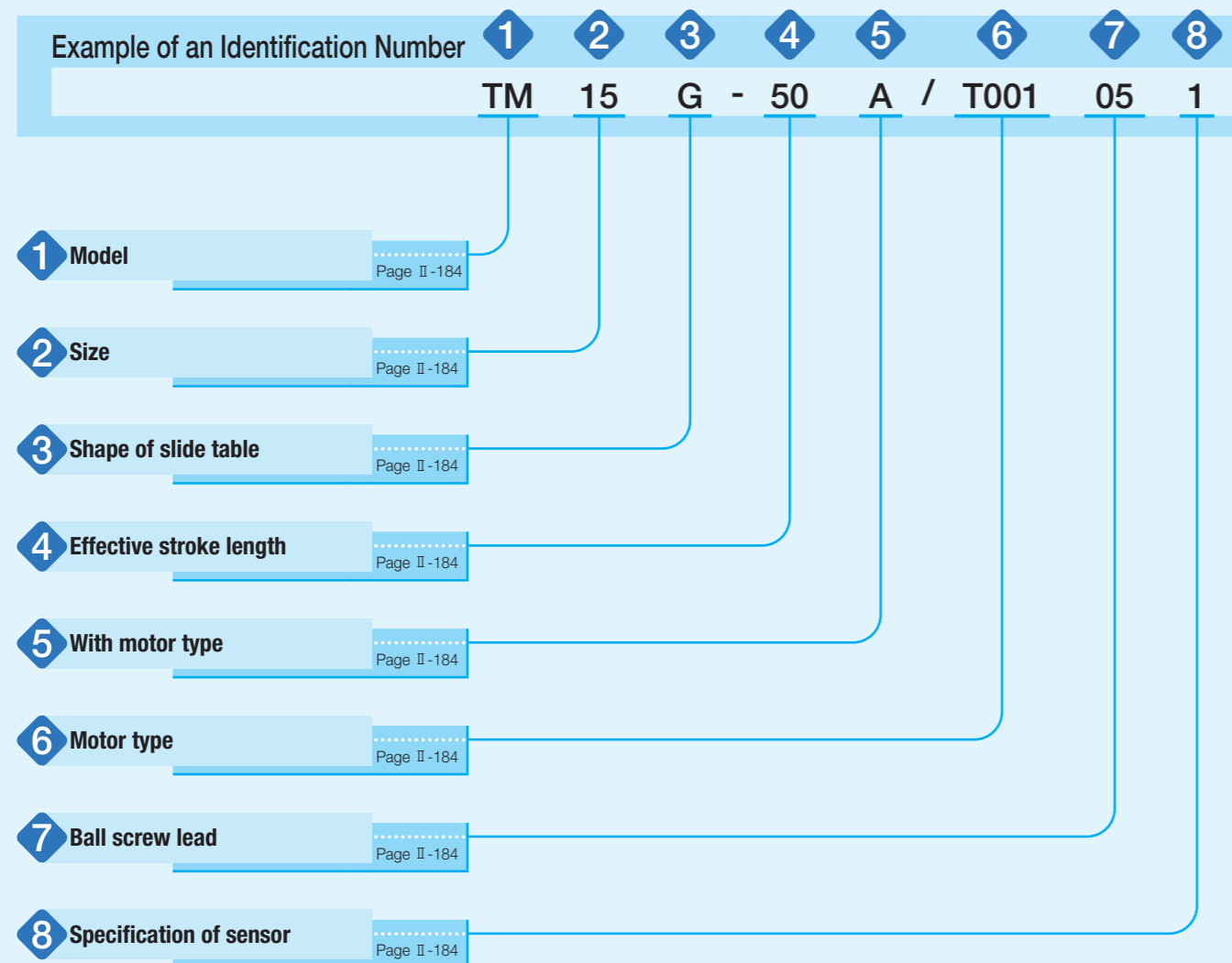

Identification Number and Specification

- 1 Model: TM: Micro Precision Positioning Table TM
- 2 Size: 15: Table width 15mm
- 3 Shape of slide table: No symbol: Standard table G: Long table
- 4 Effective stroke length: Select a effective stroke length from the list of Table 1.

Table 1 Shape of slide table and effective stroke length

Shape of slide table	Effective stroke length mm
Standard table	20、40、60
Long table	10、30、50

- 5 With motor type: A: With motor
- 6 Motor type:
 - T001: AC servomotor (standard type)
 - T002: Stepper motor (five phases)
 - T003: Stepper motor (two phases)
 - T004: AC servomotor (high torque type)

When T004 is specified, the ball screw lead of 0.5mm in 7 cannot be specified.
For details of motor specification, see pages II-188 and II-191.
If you use a non-standard motor, contact **IKO**.
- 7 Ball screw lead:
 - 05: Lead 0.5mm
 - 10: Lead 1.0mm
 - 15: Lead 1.5mm

When the ball screw lead of 0.5mm is specified, T004: AC servomotor (high torque type) in 6 cannot be specified.
- 8 Specification of sensor:
 - 0: Without sensor
 - 1: With sensor (on the right as viewed from the side opposite the motor)
 - 2: With sensor (on the left as viewed from the side opposite the motor)

Once you select "Without sensor", adding a sensor afterward is not allowed.
If "With sensor" is selected, the directions of wirings for the motor and the sensor are the same direction.

Remark: A resin table cover is used but a stainless table cover can also be manufactured. If needed, please contact **IKO**.

Specifications

Table 2 Accuracy

unit: mm

Model	Ball screw lead	Positioning repeatability	Positioning accuracy
TM15 -20	0.5	±0.001	0.015
	1	±0.002	
	1.5		
TM15 -40	0.5	±0.001	0.015
	1	±0.002	
	1.5		
TM15 -60	0.5	±0.001	0.015
	1	±0.002	
	1.5		
TM15G-10	0.5	±0.001	0.015
	1	±0.002	
	1.5		
TM15G-30	0.5	±0.001	0.015
	1	±0.002	
	1.5		
TM15G-50	0.5	±0.001	0.015
	1	±0.002	
	1.5		

Table 3 Maximum speed

Motor type	Number of revolutions of motor min ⁻¹	Maximum speed mm/s		
		Lead 0.5mm	Lead 1mm	Lead 1.5mm
AC servo motor	6 000	50	100	150
Stepper motor	1 800	15	30	45

Remark: To measure the practical maximum speed, it is required to consider operation patterns based on the motor to be used and load conditions.

Table 4 Maximum carrying mass

Model and size	Ball screw lead mm	Maximum carrying mass kg	
		Horizontal	Vertical
TM15	0.5	0.7	0.5
	1.0	0.7	0.5
	1.5	0.7	0.5
TM15G	0.5	1.5	0.5
	1.0	1.5	0.5
	1.5	1.5	0.5

Table 5 Specifications of ball screw

unit: mm

Model and size	Shape of slide table	Stroke	Shaft dia.	Overall length
TM15	Standard	20	2	54
		40		74
		60		94
	Long	10		54
		30		74
		50		94

Table 6 Table inertia, coupling inertia, and starting torque

Model and size	Table inertia J_T $\times 10^{-5} \text{kg} \cdot \text{m}^2$			Coupling inertia J_C $\times 10^{-5} \text{kg} \cdot \text{m}^2$	Starting torque T_s N·m
	Lead 0.5mm	Lead 1mm	Lead 1.5mm		
TM15 -20	0.00013	0.00016	0.00022	0.0028	0.005
TM15 -40	0.00016	0.00019	0.00024		
TM15 -60	0.00018	0.00021	0.00026		
TM15G-10	0.00014	0.00019	0.00028		
TM15G-30	0.00016	0.00021	0.00030		
TM15G-50	0.00018	0.00023	0.00032		

Sensor Specification

Table 7 Sensor timing chart

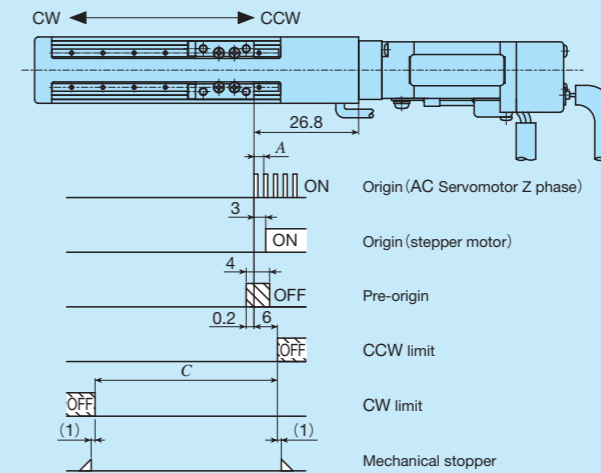

unit: mm

Model and size	Ball screw lead	A	Effective stroke length ⁽¹⁾	C (Ref.)
TM15 -20	0.5	0.25	20	Effective stroke length+2
	1	0.5		
	1.5	0.75		
TM15 -40	0.5	0.25	40	Effective stroke length+2
	1	0.5		
	1.5	0.75		
TM15 -60	0.5	0.25	60	Effective stroke length+2
	1	0.5		
	1.5	0.75		
TM15G-10	0.5	0.25	10	Effective stroke length+0.5
	1	0.5		
	1.5	0.75		
TM15G-30	0.5	0.25	30	Effective stroke length+0.5
	1	0.5		
	1.5	0.75		
TM15G-50	0.5	0.25	50	Effective stroke length+0.5
	1	0.5		
	1.5	0.75		

Note (1) The sensor position cannot be adjusted. The effective stroke length indicates the stroke length that can be surely secured between the limit sensors.

Remarks 1. "With sensor" or "Without sensor", and wiring directions are specified using the corresponding identification number.
2. For the specifications of respective sensors, please see the section of sensor specification in General Explanation.

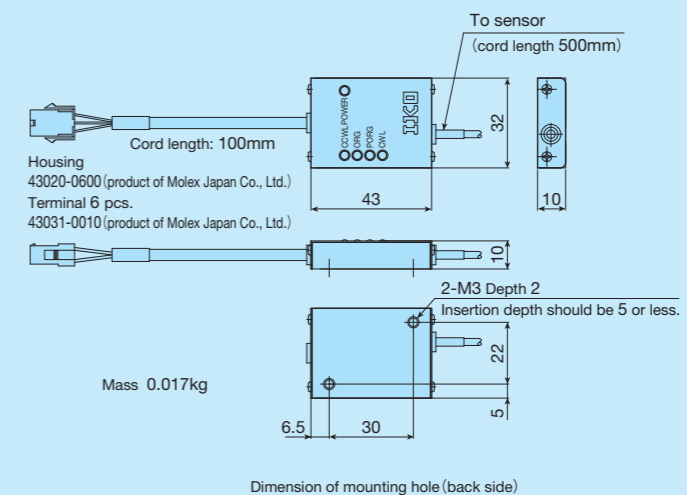
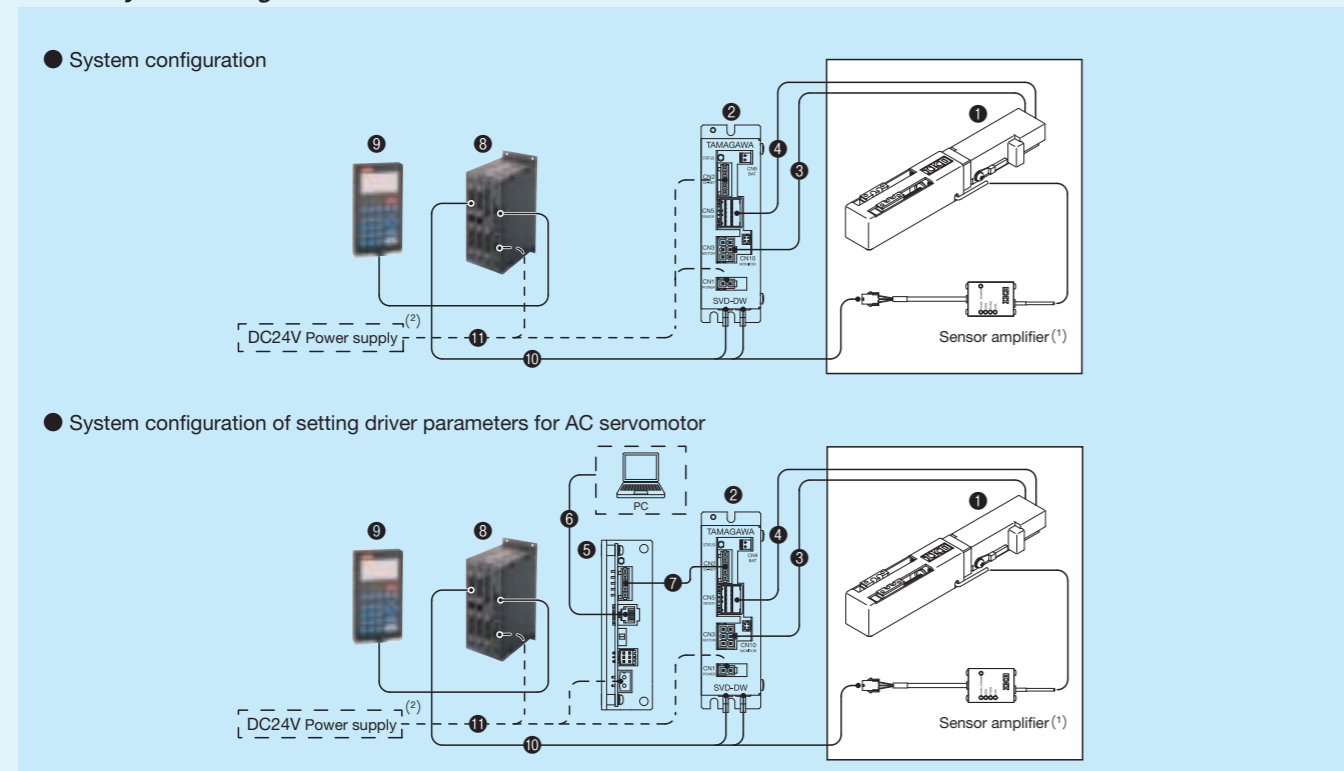

Fig.1 Outside dimension of sensor amplifier

System Configuration

Dedicated driver for Micro Precision Positioning Table TM is provided. The following table shows its typical system configuration. For the specifications of the driver, please see the section of specifications of motor and driver on page II-188 to page II-192. When you place an order, please specify desired model numbers from the list of following table.

Table 8 System configuration



No.	Name	Model number			
1	Motor code	T001 AC servomotor (standard type)	T004 AC servomotor (high torque type)	T002 Stepper motor (five phases)	T003 Stepper motor (two phases)
2	Driver	TA8410N7318E936	TA8410N7318E951	TD-5M13-L	eTD-24A
3	Motor cord	EU9614N□0		TAE20S6-SM0□ (TAE20S7-SN0□)	TAE20S8-SM0□ (TAE20S9-SN0□)
4	Resolver cord	EU9615N□0		-	-
5	Communication unit ⁽³⁾	TA8433N211		-	-
6	RS-232C cord ⁽³⁾	EU6517N2		-	-
7	SV-NET cord ⁽³⁾	EU9610N20□0		-	-
8	Programmable controller	CTN481G			
9	Teaching box	TAE10M5-TB			
10	Pulse cord and limit cord ⁽⁴⁾	TAE10U5-LD0□ (TAE10U6-LD0□)	TAE10U7-LD0□ (TAE10U8-LD0□)	TAE10U9-LD0□ (TAE10V0-LD0□)	
11	Power cord	This must be prepared by customer. ⁽⁵⁾			This must be prepared by customer. ⁽⁶⁾

- Notes (1) Once you select "Without sensor", no sensor amplifier will be attached.
 (2) DC24V power supply must be prepared separately by customer.
 (3) This is required for in setting parameters. Please see the section of parameter setting for driver. For specifications of communication units, please see the section of specifications of communication unit for the AC servomotor T001 and T004 on page II-190.
 (4) If the customer uses any other programmable controller than CTN481G, the pulse cord and limit cord must be prepared by customer.
 (5) Connectors are provided for the driver and the communication unit. Please see the section of specifications of motor and driver from page II-188 to page II-192.
 (6) Connect the power cord directly.

- Remarks 1. Cords indicated in () for motor cord, pulse cord and limit cord, and resolver cord are highly bending resistance.
 2. The lengths of motor cords, resolver cords, SV-NET cords, pulse cords and limit cords can be specified using the box (□) at the end of identification number. Up to 3m can be specified in steps of 1m.
 (For 3m: EU9614N30, TAE10U5-LD03)
 When you use cords in excess of 3 m in length, contact **IICO**.
 3. The length of pulse cord portion of pulse cord and limit cord is 1.5 m.

Parameter setting for driver

AC servomotor for driver is required initial setting of parameters. In parameter setting, communication unit, RS232C cord, and SV-NET cord are required. Please place an order separately. Software for setting up can be downloaded from the site of Tamagawa seiki Co., Ltd. at the following: URL: http://sv-net.tamagawa-seiki.com/download/download_menu.html

These cords can be shared with more than two drivers. Please place an order according to your requirement.

Specifications of Motor and Driver

AC servomotor from Tamagawa seiki Co., Ltd. (RoHS Compliant)

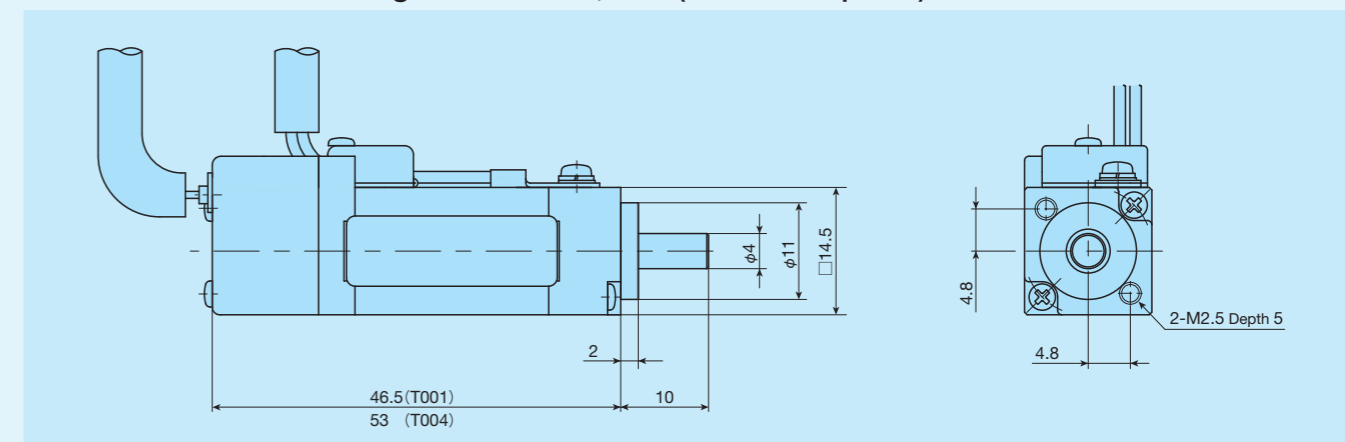

Table 9 Motor specifications

Motor code	Model number of motor	Voltage specification V	Rated output W	Rated torque N·m	Max. momentary torque N·m	Rated number of revolutions min ⁻¹	Motor inertia $J_M \times 10^{-4} \text{kg} \cdot \text{m}^2$	Resolver specification pulse/rev	Mass kg
T001	TS4861N4020E500	24	4	0.0095	0.0285	4 000	0.00064	2 048	0.05
T004	TS4862N4021E500	24	6.6	0.0159	0.0477	4 000	0.00096	2 048	0.06

Remark: Motor torque starts to decrease when the number of revolutions of motor exceeds 4,000 min⁻¹.

Table 10 Specifications of wirings for the motor and connector

Motor code T001, T004				Motor side	Mating side ⁽¹⁾
Pin No.	Code	Content	Color of lead wire		
A1	U	Motor U phase	Red	Tab housing 178964-3	Receptacle housing 178289-3
A2	V	Motor V phase	White		
A3	W	Motor W phase	Black		
B1	E	Frame ground	Green	Tab contact 175287-2	Receptacle contact 175218-2
B2	-	-	-		
B3	-	-	-		

Note (1) Mating-side connector must be prepared by customer.
 Remark: The connector is manufactured by Tyco Electronics Japan G.K..

Table 11 Specifications of wirings for the resolver and connector

Motor code T001, T004				Motor side	Mating side ⁽¹⁾
Pin No.	Code	Content	Color of lead wire		
A1	S2	Signal output	Yellow	Tab housing 1-1318115-6	Receptacle housing 1-1318118-6
A2	S1	Signal output	Red		
A3	R1	Excitation signal	White		
B1	S4	Signal output	Blue	Tab contact 1318112-1	Receptacle contact 1318108-1
B2	S3	Signal output	Black		
B3	R2	Excitation signal	Orange		

Note (1) Mating-side connector must be prepared by customer.
 Remark: The connector is manufactured by Tyco Electronics Japan G.K..

Table 12 Drivers for AC servomotor T001 and T004 from Tamagawa seiki Co., Ltd. (RoHS compliant)

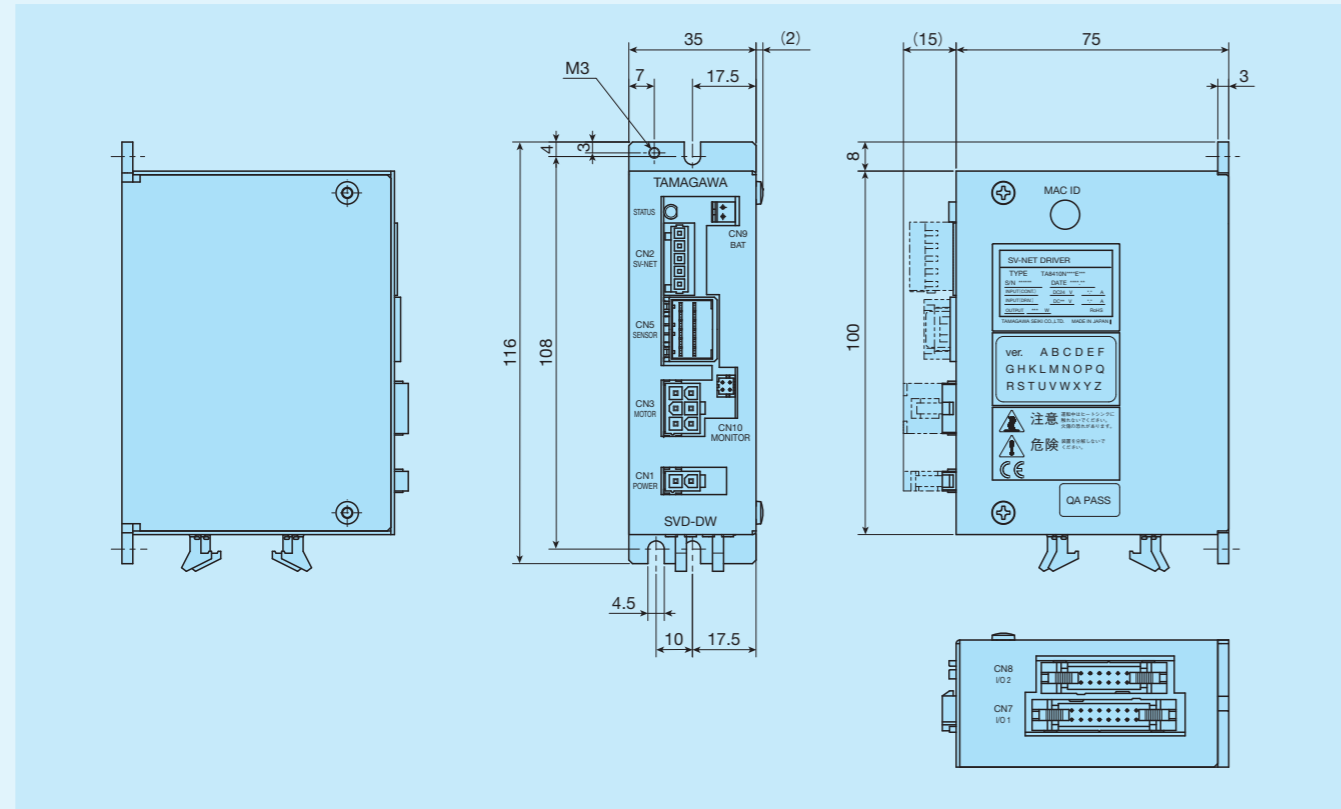

No.	Name	Function
①	CN1	Driving power supply connector
②	CN2	SV-NET connector
		Control power supply connector
③	CN3	Motor connector
④	CN5	Sensor connector
⑤	CN7	I/O connector
	CN8	I/O connector

Table 13 Specifications of AC servomotor T001 and T004

	TA8410N7318E936	TA8410N7318E951
Model number of driver	TA8410N7318E936	TA8410N7318E951
Applicable motor code	T001	T004
Rated output of applicable motor	4W	6.6W
Feedback	Brushless resolver	
Specified system of pulse input	CW/CCW signal, pulse signal/rotational direction signal	
Specified method of pulse input	Line driver, open collector	
Main circuit power supply voltage	DC24V ±10%	
Control circuit power supply	DC24V ±10%	
Continuous output current Arms	0.68	1.000
Maximum output current Arms	1.92	2.875
Operating temperature range	0~40°C	
Storage temperature range	-20~85°C (keep freeze free)	
Operating humidity	90% or less (keep dewdrop free)	
Mass kg	0.30	

Remark: DC24V power supply must be prepared by customer.

Table 14 Accessories of drivers for AC servomotor T001 and T004

Name	Content	Model number	Remark
CN1	Driving power supply connector	Receptacle housing	Product of Molex Japan Co., Ltd.
		Terminal	
CN2	Control power supply connector	Connector plug	734-105
CN7	I/O connector	Socket	HIF3BA-16D-2.54R
CN8	I/O connector	Socket	HIF3BA-14D-2.54R
CN10	Connectors for analog monitor	Socket	DF-4DS-2C
		Contact	DF11-2428SC

Table 15 Communication unit for AC servomotor T001 and T004 from Tamagawa seiki Co., Ltd. (RoHS compliant)

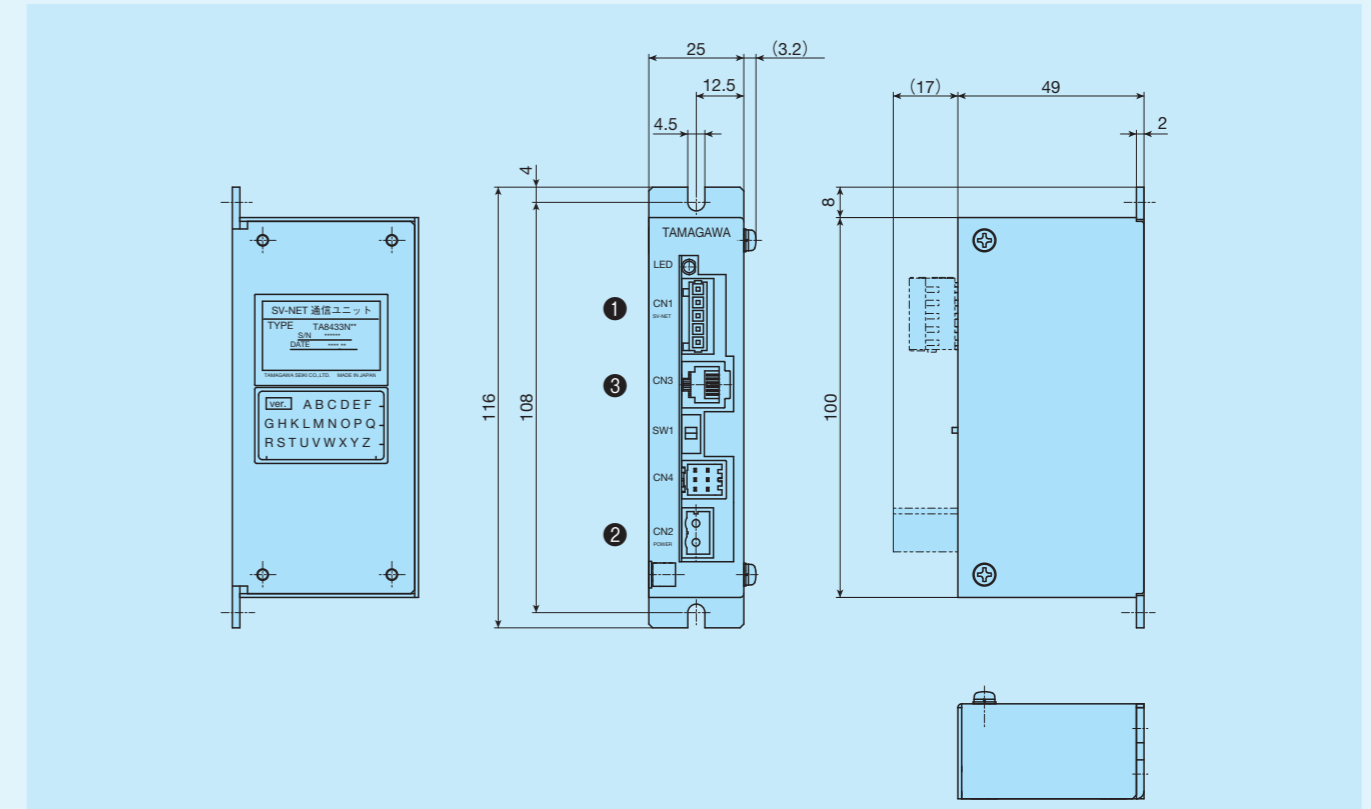

No.	Name	Function
①	CN1	Communication connector
②	CN2	Power supply connector
③	CN3	Connector

Remark: Communication unit is used when setting parameters for driver. For system configurations when setting parameters, please see the section of system configuration on page II-187.

Table 16 Specifications of communication units for AC servomotor T001 and T004

Model number for communication unit	TA8433N211	
Input power voltage	DC24V ±10% (current consumption of unit 0.1A)	
Control power supply output voltage	DC24V ±10%	
Communication specifications	PC side	RS232C cable
	Driver side	SV-NET cord
Operating temperature range	0~40°C	
Storage temperature range	-10~85°C (keep freeze free)	
Operating humidity	90% or less (keep dewdrop free)	
Mass kg	0.2	

Remark: DC24V power supply must be prepared by customer.

Table 17 Accessories of communication units for AC servomotor T001 and T004

Name	Content	Model number	Remark
CN1	Communication connector	Connector plug	734-105
CN2	Power supply connector	Connector plug	

Stepper motor from Tamagawa seiki Co., Ltd. (RoHS Compliant)

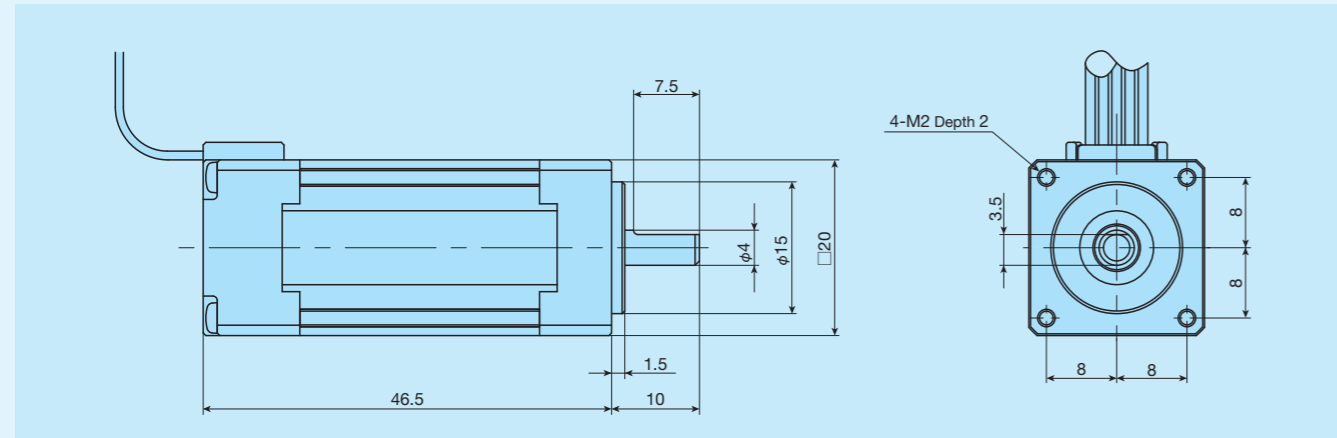

Table 18 Motor specifications

Motor code	Model number of motor	Step angle	Maximum holding torque N · m	Current A/phase	Rotor inertia $J_M \times 10^{-4} \text{kg} \cdot \text{m}^2$	Mass (Ref.) kg
T002	TS3682N2	0.72	0.024	0.35	0.004	0.085
T003	TS3692N2	1.80	0.024	0.35	0.004	0.085

Table 19 Specifications of wirings for the motor and connector

Pin No.	Color of lead wire		Motor side	Mating side ⁽¹⁾
	Motor code T002	Motor code T003		
1	Blue	Black	Housing 43025-0600	Housing 43020-0600
2	Red	Not use		
3	Orange	Blue		
4	Green	Red	Terminal 43030-0007	Terminal 43031-0007
5	Black	Orange		
6	Not use	Green		

Note (1) Mating-side connector must be prepared by customer.
Remark: Connectors are manufactured by Molex Japan Co., Ltd.

Table 20 Driver for stepper motor T002 from Tohan Denshi Kiki Co.,Ltd. (RoHS compliant)

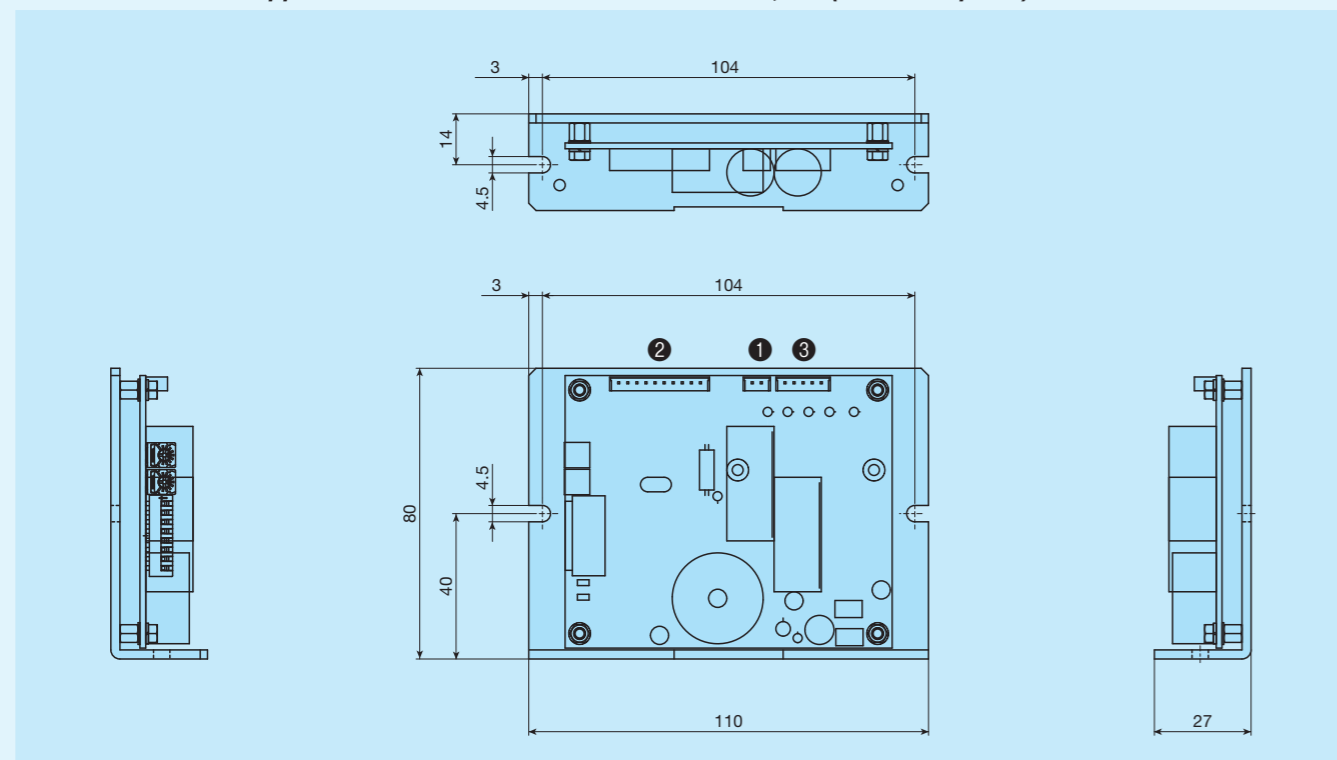

No.	Name	Function
①	CN1 Power supply connector	Connect a power supply to this connector.
②	CN2 I/O connector	Connect a pulse cord to this connector.
③	CN3 Motor connector	Connect a motor cord to this connector.

Table 21 Specifications of driver for stepper motor T002

Model number of driver	TD-5M13-L
Applicable motor code	T002
Excitation type	Micro step Max. 500 divisions
Input method	Photo coupler Input resistance 220Ω
Input format	CW/CCW signal Pulse signal/rotational direction signal
Power input	DC15 to 35V 2.5A
Ambient temperature (in operation)	0~40°C (keep freeze free)
Ambient humidity (in operation)	85% or lower (keep dewdrop free)
Mass kg	0.17

Remark: DC24V is recommended for power input. The power supply must be prepared by customer.

Table 22 Accessories of drivers for stepper motor T002

Name	Model number		Remark
	Housing	Contact	
CN1 Power supply connector	EHR-2	BEH-001T-P0.6	JST Mfg. Co., Ltd.
CN2 Control signal connectors	EHR-10		
CN3 Driving power supply connector	EHR-5		

Table 23 Driver for Stepper motor T003 from Tohan Denshi Kiki Co.,Ltd. (RoHS compliant)

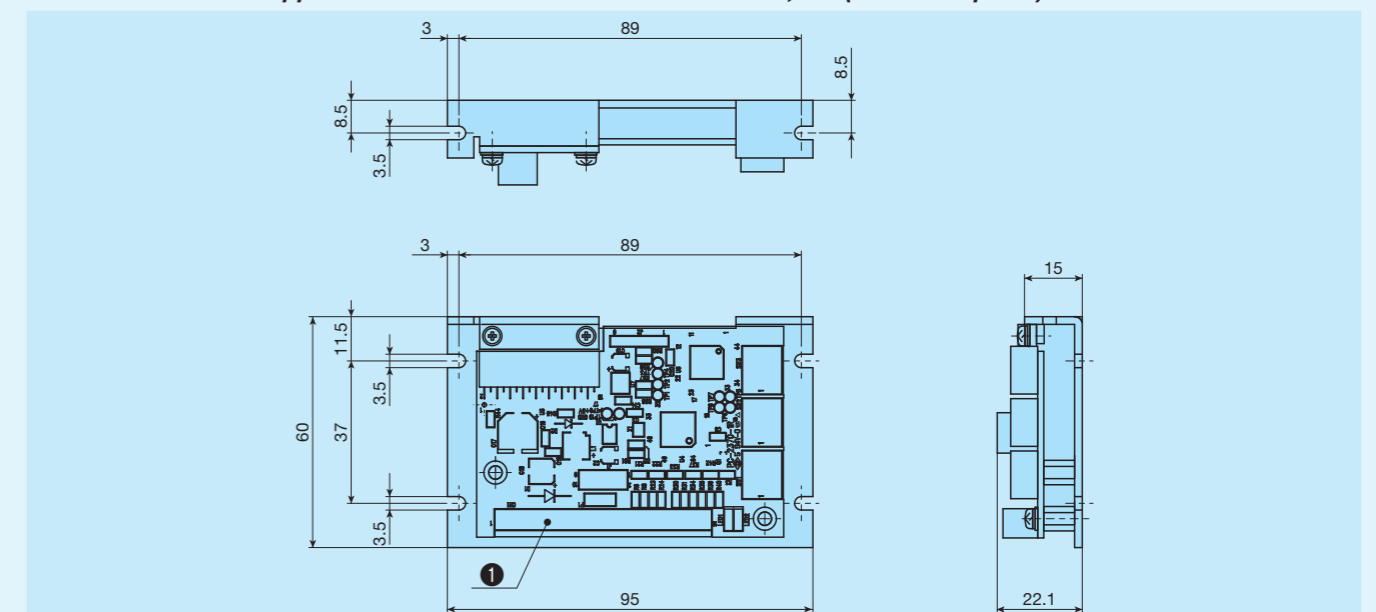

No.	Name	Function
①	I/F connector	Connect power, pulse, and motor cords to this connector.

Table 24 Specification of driver for stepper motor T003

Model number of driver	eTD-24A
Applicable motor code	T003
Excitation type	Micro step Max. 500 divisions
Input method	Photo coupler Input resistance 220Ω
Input format	CW/CCW signal Pulse signal/rotational direction signal
Power input	DC24V±10% 3A
Ambient temperature (in operation)	0~40°C (keep freeze free)
Ambient humidity (in operation)	85% or lower (keep dewdrop free)
Mass kg	0.06

Remark: DC24V power supply must be prepared by customer.

Torque chart for stepper motor T002

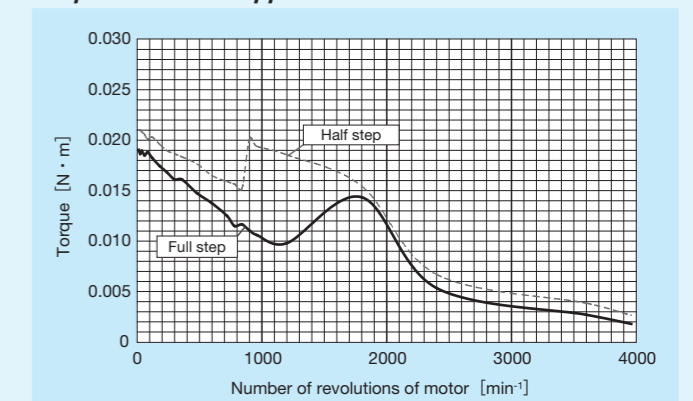

Motor code	Model number of motor	Model number of driver
T002	TS3682N2	TD-5M13-L

Table 24 Specification of driver for stepper motor T003

Torque chart for stepper motor T003

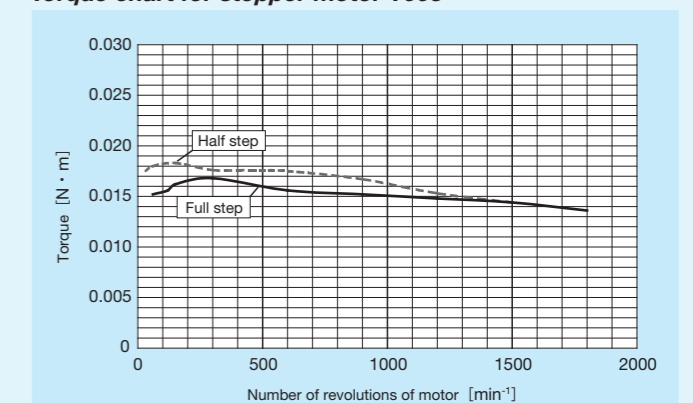

Motor code	Model number of motor	Model number of driver
T003	TS3692N2	eTD-24A

1N=0.102kgf=0.2248lbs.
1mm=0.03937inch

TM15 Specifications of AC servomotor

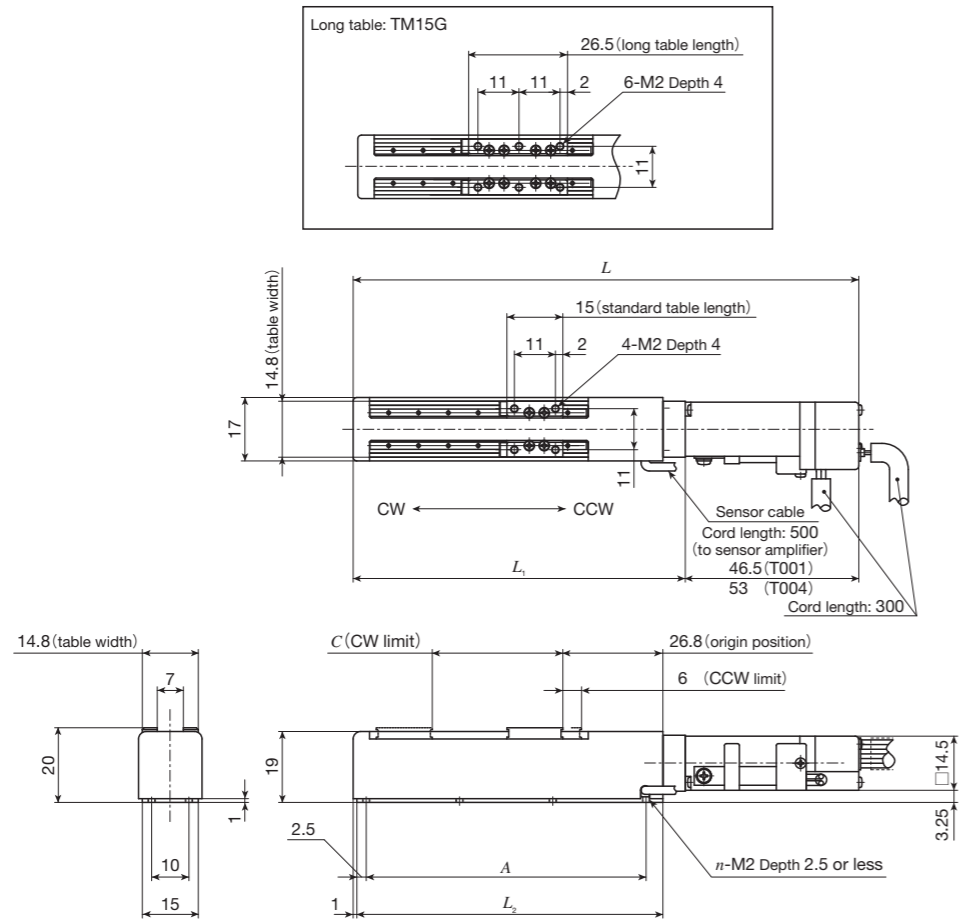

unit: mm

Model and size	Stroke length		Dimensions of table						Mass ⁽¹⁾ (Ref.) kg
	Effective stroke length ⁽²⁾	CW limit position C	Overall length L		L_1	L_2	Mounting holes of bed A (the number of holes×pitch)		
			T001	T004			n		
TM15 -20	20	16	115.5	122	69	62	50 (2×25)	6	0.15
TM15 -40	40	36	135.5	142	89	82	75 (3×25)	8	0.16
TM15 -60	60	56	155.5	162	109	102	96 (4×24)	10	0.17
TM15G-10	10	4.5	115.5	122	69	62	50 (2×25)	6	0.16
TM15G-30	30	24.5	135.5	142	89	82	75 (3×25)	8	0.17
TM15G-50	50	44.5	155.5	162	109	102	96 (4×24)	10	0.18

Notes ⁽¹⁾ Represents value when T001 is specified. It will be 0.01kg heavier when T004 is specified.

⁽²⁾ The sensor position cannot be adjusted. The effective stroke length indicates the stroke length that can be surely secured between the limit sensors.

Remark: A resin table cover is used but a stainless table cover can also be manufactured. If needed, please contact **IKO**.

TM15 Specifications of stepper motor

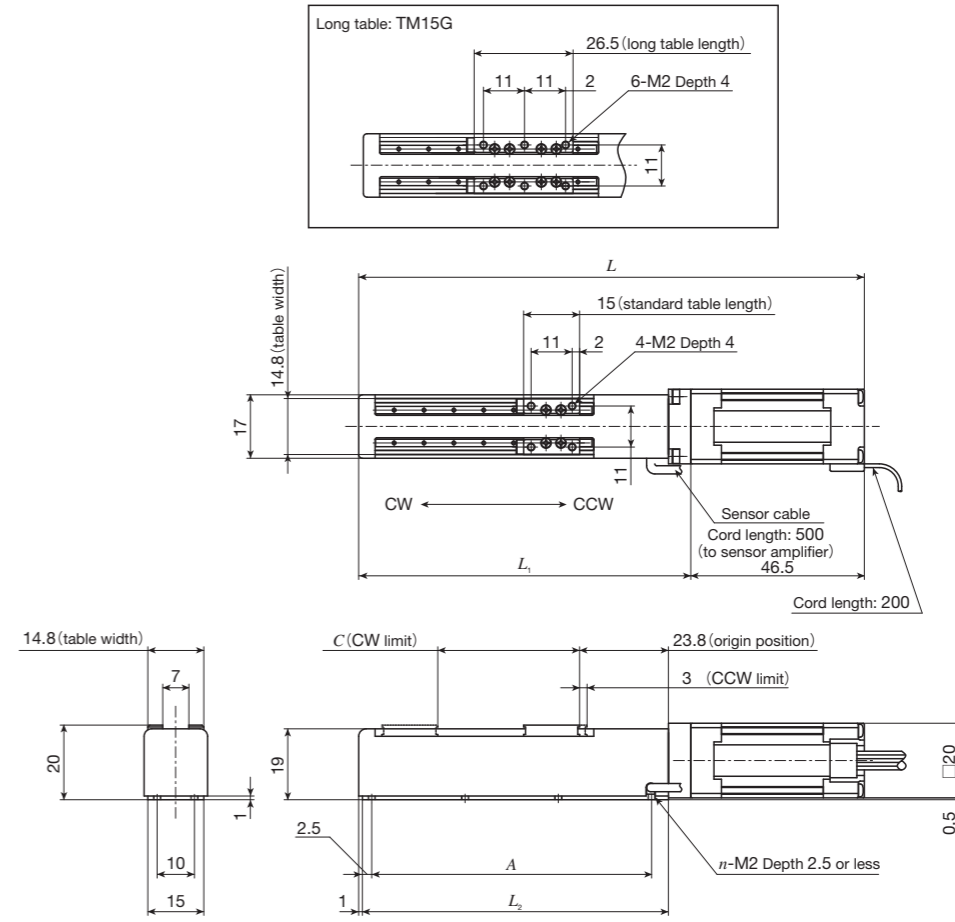

unit: mm

Model and size	Stroke length		Dimensions of table						Mass (Ref.) kg
	Effective stroke length ⁽¹⁾	CW limit position C	Overall length L		L_1	L_2	Mounting holes of bed A (the number of holes×pitch)		
			L_1	L_2			n		
TM15 -20	20	19	115.5	122	69	62	50 (2×25)	6	0.18
TM15 -40	40	39	135.5	142	89	82	75 (3×25)	8	0.19
TM15 -60	60	59	155.5	162	109	102	96 (4×24)	10	0.20
TM15G-10	10	7.5	115.5	122	69	62	50 (2×25)	6	0.19
TM15G-30	30	27.5	135.5	142	89	82	75 (3×25)	8	0.20
TM15G-50	50	47.5	155.5	162	109	102	96 (4×24)	10	0.21

Note ⁽¹⁾ The sensor position cannot be adjusted. The effective stroke length indicates the stroke length that can be surely secured between the limit sensors.

Remark: A resin table cover is used but a stainless table cover can also be manufactured. If needed, please contact **IKO**.