

Combined Bearing/Freewheel

CSK CSK..2RS



TYPE

CSK..2RS



CSK

Type CSK is a sprag type freewheel integrated into a 62 series ball bearing (except sizes 8 and 40). It is bearing supported, delivered grease lubricated and protected against dust of more than 0,3 mm. The use of additional “nylos” type seals is recommended especially when the working temperature exceeds 50°C. Oil bath lubrication is also possible.

All the CSK versions are equipped with

“formchromed” sprags. This process increases several times the overrunning life time. Torque transmission is ensured by a press fit assembly into a rigid steel housing with N6 tolerance, and onto a shaft with n6 tolerance. For this reason, the initial bearing radial clearance is set at C5.

Please contact us when either the ambient or the operating temperature is not within the range +5°C to +60°C. CSK..2RS is 5 mm wider but is equipped with lip seals to be water splash resistant.

Combined Bearing/Freewheel

CSK, CSK..2RS

CSK

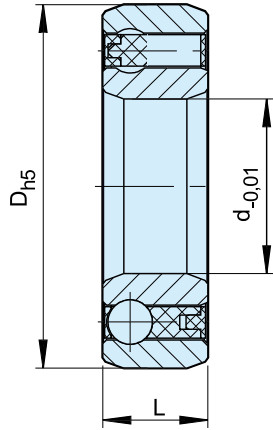

CSK..2RS

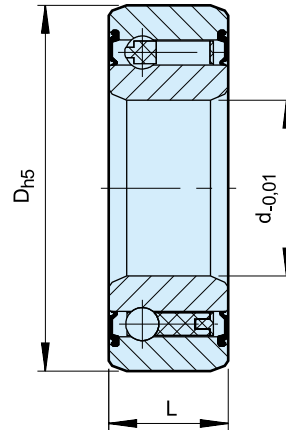

Type	Size	Bearing series					Bearing loads		Weight	Drag torque
			$T_{KN}^{1)}$ [Nm]	n_{max} [min ⁻¹]	D [mm]	L [mm]	C [kN]	C ₀ [kN]		
CSK (KK)	d [mm]									
	8*	–	2,5	15000	22	9	3,28	0,86	0,015	0,5
	12	6201	9,3	10000	32	10	6,1	2,77	0,04	0,7
	15	6202	17	8400	35	11	7,4	3,42	0,06	0,9
	17	6203	30	7350	40	12	7,9	3,8	0,070	1,1
	20	6204	50	6000	47	14	9,4	4,46	0,110	1,3
	25	6205	85	5200	52	15	10,7	5,46	0,140	2,0
	30	6206	138	4200	62	16	11,7	6,45	0,210	4,4
	35	6207	175	3600	72	17	12,6	7,28	0,300	5,8
40	–	325	3000	80	22	15,54	12,25	0,5	7,0	
CSK..2RS	8**		2,5	15000	22	9	3,28	0,86	0,015	0,8
	12	–	9,3	10000	32	14	6,1	2,77	0,05	3,0
	15		17	8400	35	16	7,4	3,42	0,070	4,0
	17		30	7350	40	17	7,9	3,8	0,09	5,6
	20		50	6000	47	19	9,4	4,46	0,145	6,0
	25		85	5200	52	20	10,7	5,46	0,175	6,0
	30		138	4200	62	21	11,7	6,45	0,270	7,5
	35		175	3600	72	22	12,6	7,28	0,400	8,2
	40	–	325	3000	80	27	15,54	12,25	0,6	10

NOTES

1) $T_{max} = 2 \times T_{KN}$

» Refer to Selection page 7 to 11

*) One Z seal on the bearing side only. Looking from this side, the outer race runs free in the counterclockwise direction

**) Only one RS seal on the ball bearing side looking from this side, the outer race runs free in the counterclockwise direction

» Refer to mounting and maintenance instructions page 12 to 13

MOUNTING EXAMPLES

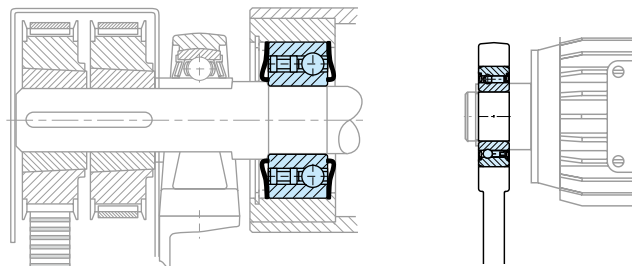

Combined Bearing/Freewheel

CSK..P, CSK..PP CSK..P-2RS



TYPE

CSK..P

CSK..PP



Types CSK..P and CSK..PP are sprag type freewheels integrated into 62.. series ball bearings (except size 40). They are bearing supported, delivered grease lubricated and protected against dust of more than 0,3 mm.

The use of additional “nylos” type seals is recommended especially when the working temperature exceeds 50°C. Oil bath lubrication is also possible.

In addition to the basic CSK model, type CSK..P

features a keyway on the inner race. For this reason it can be keyed to a shaft to k6 tolerance. The outer race must still be pressed into a rigid steel housing to N6 tolerance.

CSK..PP features a keyway on both the inner and outer race. The recommended mounting tolerances are h6 on the shaft and H6 in a rigid housing. Please contact us when either the ambient or the operating temperature is not within the range +5°C to +60°C.

Combined Bearing/Freewheel

CSK..P, CSK..PP, CSK..P-2RS

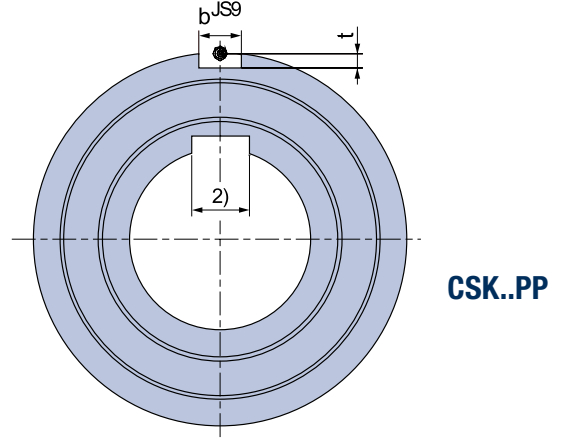
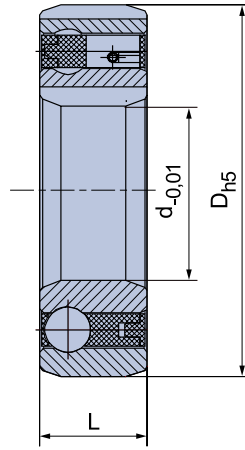
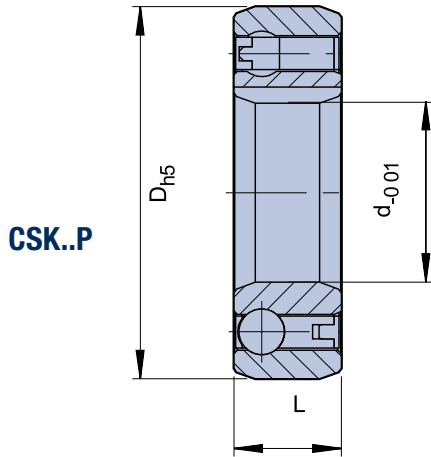

Type	Size	Bearing series							Bearing loads		Weight	Drag torque
			$T_{KN}^{1)}$ [Nm]	n_{max} [min ⁻¹]	D [mm]	L [mm]	b [mm]	t [mm]	C [kN]	C ₀ [kN]		
CSK..P ²⁾	12	6201	9,3	10000	32	10			6,1	2,77	0,04	0,7
	15	6202	17	8400	35	11			7,4	3,42	0,06	0,9
	17	6203	30	7350	40	12			7,9	3,8	0,070	1,1
	20	6204	50	6000	47	14			9,4	4,46	0,110	1,3
	25	6205	85	5200	52	15			10,7	5,46	0,140	2,0
	30	6206	138	4200	62	16			11,7	6,45	0,210	4,4
	35	6207	175	3600	72	17			12,6	7,28	0,300	5,8
	40	–	325	3000	80	22			15,54	12,25	0,5	7,0
CSK..PP ²⁾	15	6202	17	8400	35	11	2	0,6	7,4	3,42	0,06	0,9
	17	6203	30	7350	40	12	2	1,0	7,9	3,8	0,070	1,1
	20	6204	50	6000	47	14	3	1,5	9,4	4,46	0,110	1,3
	25	6205	85	5200	52	15	6	2,0	10,7	5,46	0,140	2,0
	30	6206	138	4200	62	16	6	2,0	11,7	6,45	0,210	4,4
	35	6207	175	3600	72	17	8	2,5	12,6	7,28	0,300	5,8
	40	–	325	3000	80	22	10	3,0	15,54	12,25	0,5	7,0
CSK..P-2RS ²⁾	12	–	9,3	10000	32	14			6,1	2,77	0,05	3
	15	–	17	8400	35	16			7,4	3,42	0,07	4
	17	–	30	7350	40	17			7,9	3,8	0,09	5,6
	20	–	50	6000	47	19			9,4	4,46	0,145	6,0
	25	–	85	5200	52	20			10,7	5,46	0,175	6,0
	30	–	138	4200	62	21			11,7	6,45	0,270	7,5
	35	–	175	3600	72	22			12,6	7,28	0,4	8,2
	40	–	325	3000	80	27			15,54	12,25	0,6	10

NOTES

1) $T_{max} = 2 \times T_{KN}$
» Refer to Selection page 7 to 11

2) Keyway to DIN 6885.3
Size 40 keyway to DIN 6885.1

» Refer to mounting and maintenance instructions
page 12 to 13

MOUNTING EXAMPLE

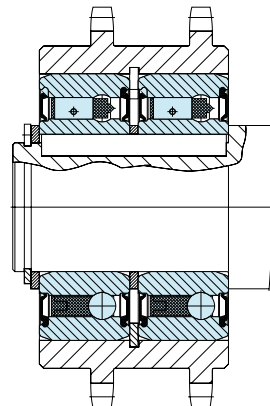

Combined Bearing/Freewheel

ASK



TYPE



Type ASK is a roller type freewheel bearing supported by two rows of roller bearings. It is a self-contained dust protected unit, delivered grease lubricated.

Nominal outside dimensions are the same as a 60.. series bearing. Torque transmission must be ensured by a press fit on both the inner and outer race. Because of this press fit, the standard radial clearance is C4. The interference tolerances are on the freewheel dimensions,

allowing a direct mounting in a standard series 60.. bearing location: Shaft tolerance should be h6 or j6 The outer race should be pressed into a rigid housing to K6 tolerance.

Radial bearing load capacities are given in the table. Type ASK freewheels can not accept axial loading. In cases of such loads, thrust bearings must be provided.

Combined Bearing/Freewheel

ASK

ASK

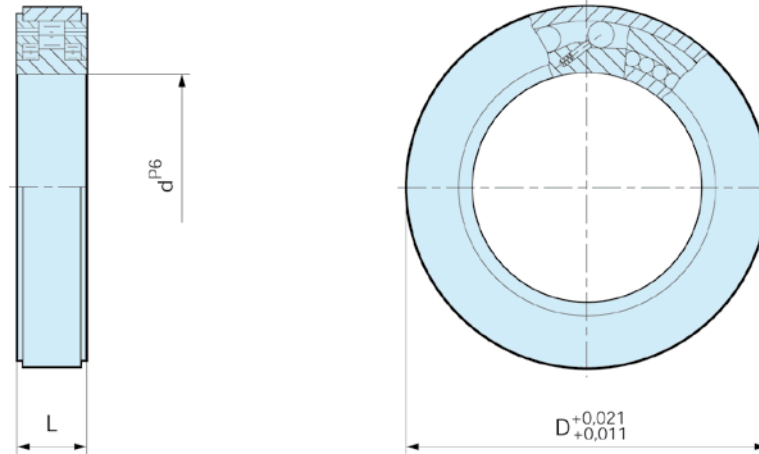

Type	Size	Bearing series					Bearing loads		Weight	Drag torque
			$T_{KN}^{1)}$ [Nm]	n_{max} [min ⁻¹]	D [mm]	L [mm]	dynamic C [kN]	static C ₀ [kN]		
ASK	d ^{P6} [mm]									
	40	6008	72	3500	68	15	16	20,6	0,25	15
	50	6010	125	2200	80	16	19,6	23,5	0,34	20
	60	6012	250	1800	95	18	25,3	35,1	0,5	25

NOTES

1) $T_{max} = 2 \times T_{KN}$

» Refer to Selection page 7 to 11

» Refer to mounting and maintenance instructions page 12 to 13

MOUNTING EXAMPLE

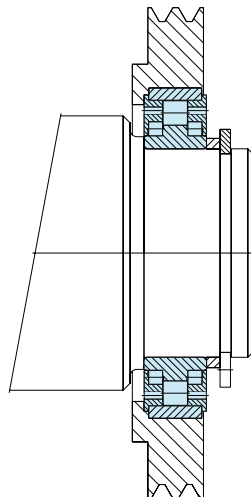

Combined Bearing/Freewheel

GFK



TYPE



Type GFK is a sprag type freewheel integrated into a 59.. series ball bearing. This design provides high torque capacity for minimal outside diameter. It is a bearing supported type, delivered grease lubricated.

Oil bath lubrication is also possible. Whatever the lubrication type, seals should be provided, as illustrated on the next page.

Torque transmission must be ensured by a press fit assembly into a rigid outer housing with R6 tolerance, and onto a shaft with p5 tolerance.

Initial radial clearance has been provided to take into account this heavy press fit. Operating temperature range: -20°C to $+100^{\circ}\text{C}$. Peaks up to $+120^{\circ}\text{C}$ are acceptable for short periods. Please contact us for higher temperatures.

Combined Bearing/Freewheel

GFK

GFK

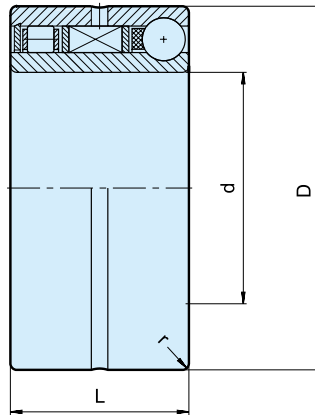

Type	Size	Overrunning speeds			Bearing series	Loads							Weight [kg]
		$T_{KN}^{1)}$ [Nm]	$n_{imax}^{2)}$ [min ⁻¹]	$n_{amax}^{3)}$ [min ⁻¹]		Rollers dyn. C [N]	Balls dyn. C [N]	Rollers stat. C₀ [N]	Balls stat. C₀ [N]	D [mm]	L [mm]	r [mm]	
GFK	20	51	5500	4000	5904	5600	4400	2900	2750	37	23	0,5	0,09
	25	65	5300	3800	5905	6300	5300	3450	3350	42	23	0,5	0,11
	30	95	5000	3500	5906	7700	5500	4600	3650	47	23	0,5	0,13
	35	204	4600	3200	5907	8200	8500	5200	5700	55	27	1	0,20
	40	315	4200	3000	5908	8650	9300	5750	6700	62	30	1	0,30
	45	370	3800	2500	5909	9200	9700	6350	7300	68	30	1	0,34

NOTES

1) $T_{max} = 2 \times T_{KN}$
 » Refer to Selection page 7 to 11

2) Inner race overruns

3) Outer race overruns

» Refer to mounting and maintenance instructions
 page 12 to 13

MOUNTING EXAMPLE

